

# BOLENS

HUSKY

1455

TRACTOR

MODELS 198-01 & 198-02

# ILLUSTRATED PARTS CATALOG



# BOLENS

PORT WASHINGTON, WISCONSIN, U.S.A.

PRINTED IN U.S.A.

# TRACTOR ASSEMBLY MODEL 198-01 AND 198-02

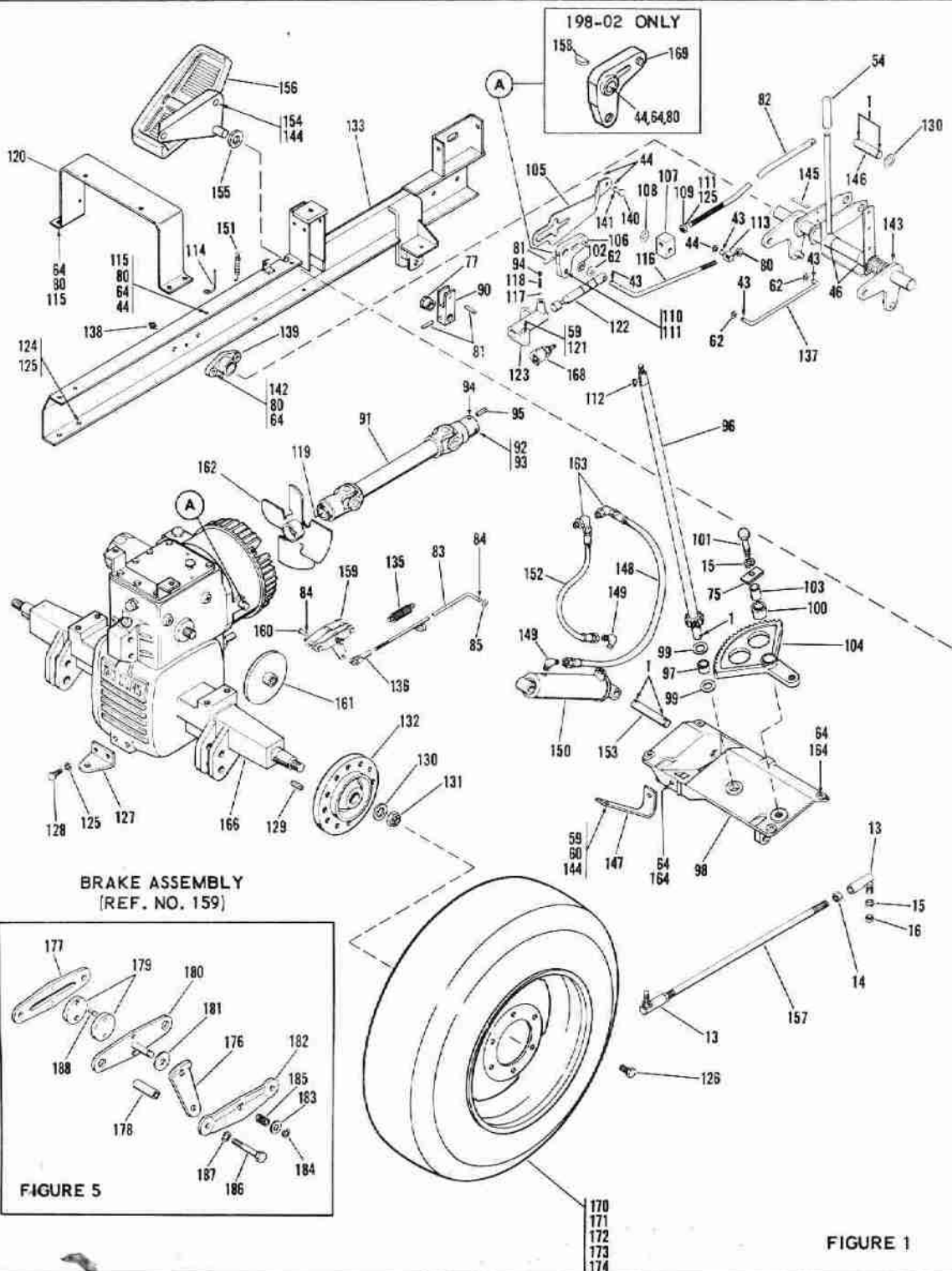

**BRAKE ASSEMBLY**  
[REF. NO. 159]

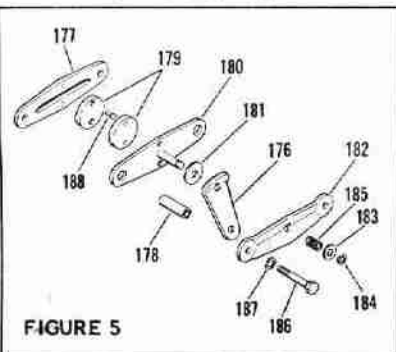

**FIGURE 5**

**FIGURE 1**

# TRACTOR ASSEMBLY MODEL 198-01 AND 198-02

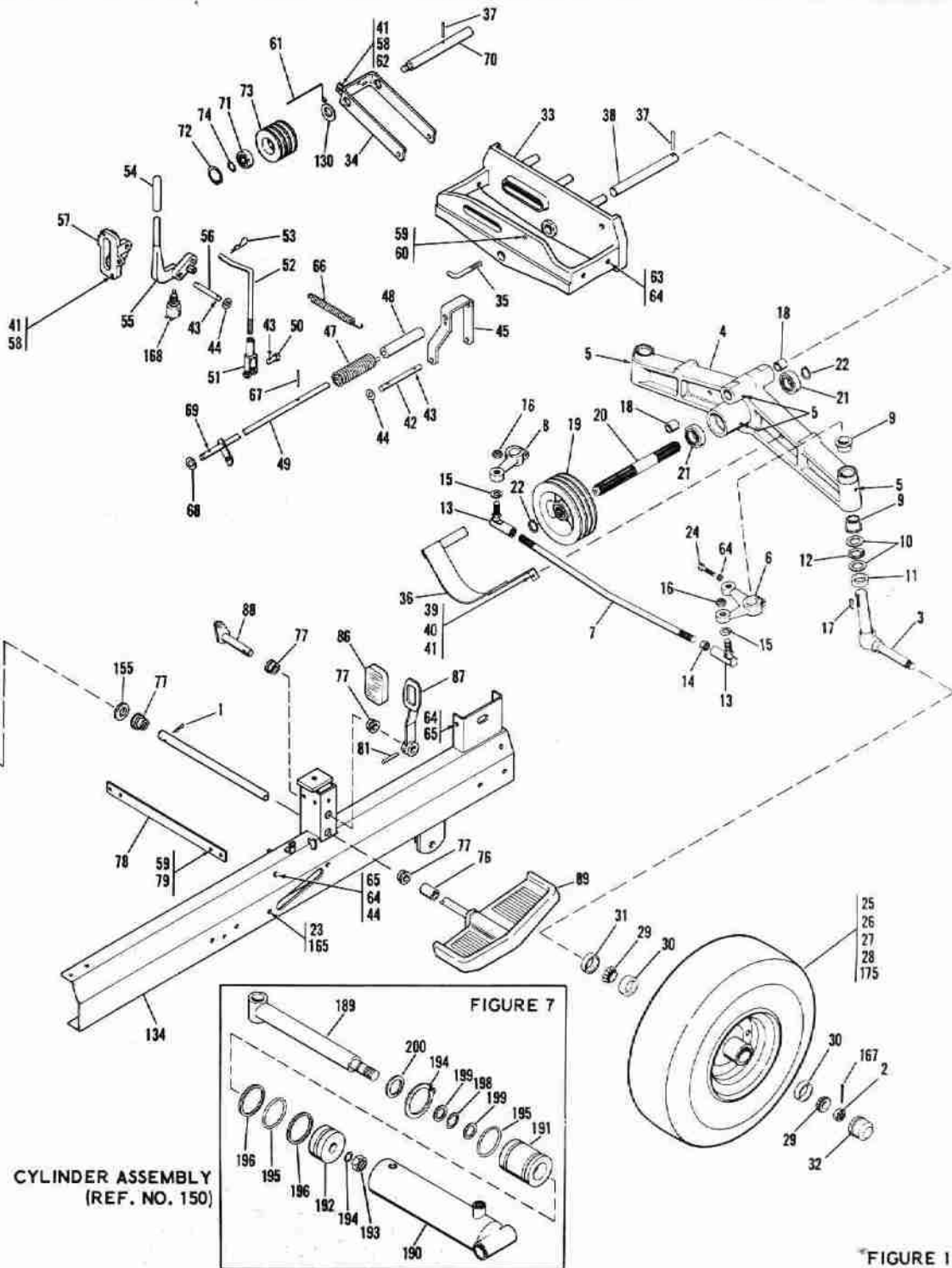

# TRACTOR ASSEMBLY MODEL 198-01 AND 198-02

## (Parts List For Figure 1)

Ref. No.	Part No.	Description	No. Req'd
1	1100 351	Cotter Pin 1/8 x 1-1/4	5
2	1185 758	Castle Nut Special - 1-14	2
3	1719 598	Wheel Spindle	2
4	1718 602	Front Axle	1
5	1104 954	Grease Fitting	4
6	1718 502	Steering Arm - R. H.	1
7	1718 575	Tie Rod	1
8	1718 513	Steering Arm - L. H.	1
9	1185 728	Flange Bearing	4
10	1185 730	Race Thrust	4
11	1706 611	Dust Seal	2
12	1185 729	Thrust Bearing	2
13	1719 003	Ball Joint	4
14	1109 533	Hex Nut 5/8 - 18	1
15	1100 247	Lockwasher 5/8	3
16	1185 082	Lock-Nut 5/8 - 18	2
17	1104 336	Square Key 1/4 x 1	4
18	1185 612	Sleeve Bearing	2
19	1718 515	PTO Sheave	1
20	1718 568	PTO Shaft	1
21	1185 100	Ball Bearing	2
22	1185 689	Retaining Ring	2
23	1108 887	Jam Nut 3/8 - 16	2
24	1107 209	Capscrew 3/8 - 24 x 1-1/2	2
25	1721 421	Wheel & Tire Assy Front (Inc Ref # 26, 27, 28)	2
26	1719 153	Tubeless Tire 5.70/5.00 x 8	2
27	1721 422	Wheel Inc. Ref 29, 30, 31, 32	2
28	1718 086	Valve Stem Only	2
29	1185 661	Roller Bearing Cone	4
30	1185 660	Roller Bearing Cup	4
31	1719 601	Felt Seal	2
32	1719 599	Cap	2
33	1718 572	Axle Support	1
34	1718 616	Idler Shaft Bail	1
35	1719 147	Belt Guide	1
36	1718 497	Belt Guide	1
37	1185 376	Roll Pin 3/16 x 1-1/2	2
38	1718 548	Axle Pivot Pin	1
39	1108 878	Capscrew 5/16 - 18 x 1	2
40	1182 563	Hex Nut 5/16 x 18	2
41	1100 242	Lockwasher 5/16	6
42	1718 533	Arm Pin	1
43	1100 346	Cotter Pin 3/32 x 3/4	10
44	1107 383	Flat Washer 3/8	11
45	1718 528	Control Arm	1
46	1720 330	Split Bushing	2
47	1718 532	Torsion Spring	1
48	1719 713	Sleeve	1
49	1718 488	Control Rod	1
50	1112 587	Clevis Pin	1
51	222 007	Clutch Yoke	1
52	1718 525	PTO Control Rod	1
53	1703 011	Spring Cotter	1
54	1718 535	Handle Grip	2
55	1718 518	Lever-PTO	1
56	1718 558	Pivot Pin	1
57	1718 508	Bracket	1
58	1106 872	Capscrew 5/16 - 18 x 5/8	4
59	1100 241	Lockwasher 1/4	10
60	1121 507	Hex Nut 1/4 - 20	3
61	1718 606	Belt Guide	1

Ref. No.	Part No.	Description	No. Req'd
62	1107 382	Flat Washer 5/16	3
63	1106 915	Capscrew 3/8 - 16 x 3/4	4
64	1100 243	Lockwasher 3/8	24
65	1106 913	Capscrew 3/8 - 16 x 5/8	6
66	1714 279	Extension Spring	1
67	1185 552	Drive Pin 3/16 x 1-3/4	1
68	1107 385	Flat Washer 1/2	2
69	1100 356	Cotter Pin 3/32 x 1	2
70	1718 567	Idler Shaft	1
71	1185 064	Ball Bearing	1
72	1187 439	Int. Retaining Ring	1
73	1719 202	Idler Sheave	1
74	1118 809	Ext. Retaining Ring	1
75	1721 405	Steering Plate	1
76	1721 378	Spacer	1
77	1185 034	Flange Bushing	4
78	1718 545	Tie Strap	1
79	1106 830	Capscrew 1/4 - 20 x 1/2	6
80	1121 509	Rex Nut 3/8 - 16	11
81	1713 432	Drive Pin 3/16 - 1-1/4	4
82	1718 541	Control Rod	1
83	1719 556	Brake Rod Assembly	1
84	1187 385	Cotter Pin 1/16 - 1/2	2
85	1107 381	Flat Washer 1/4	1
86	1719 539	Pedal Pad	1
87	1719 547	Pedal, Brake	1
88	1719 520	Brake Arm Assembly	1
89	1721 377	Speed Control Pedal	1
90	1718 544	Control Arm	1
91	1718 531	Universal Joint Ass'y	1
92	1106 888	Capscrew 5/16 - 18 x 2	1
93	1110 107	Lock Nut 5/16 - 18	1
94	1185 342	Set-Screw 5/16 - 18 x 3/8	2
95	1108 844	Square Key 1/4 x 1-1/4	1
96	1718 588	Steering Shaft	1
97	1185 319	Bronze Bearing	1
98	1719 149	Steering Bridge	1
99	1707 546	Thrust Washer	2
100	1185 711	Bronze Bearing	1
101	1107 064	Capscrew 5/8 - 11 x 2	1
102	<del>4943-182</del>	Bowed Washer <i>1719 312</i>	1
103	1718 555	Spacer	1
104	1718 506	Gear 23T	1
105	1719 540	Bracket	1
106	1719 552	Arm Ass'y (Mod 198-01 only)	1
107	1719 041	Pivot Block	1
108	1719 453	Bowed Washer	2
109	1110 110	Hex Nut 1/2 - 13	1
110	1107 037	Capscrew 1/2 - 13 x 2-1/4	2
111	1108 889	Hex Nut 1/2 x 13	3
112	1104 438	Woodruff Key 3/16 x 3/4	1
113	1714 663	Pivot Block	1
114	1711 486	Belt Guide	1
115	1106 917	Capscrew 3/8 - 16 x 7/8	1
116	1718 462	Oil Relief Spool Link	1
117	1713 416	Ball	1
118	1713 417	Compression Spring	1
119	1200 034	Key 1/4 - 7/8	1
120	1718 484	Fender Support	1
121	1106 852	Capscrew 1/4 - 20 x 2	2
122	1718 565	Oil Relief Spool	1
123	1718 521	Oil Relief Spool Guide	1

**TRACTOR ASSEMBLY MODEL 198-01 AND 198-02**  
**(Parts List For Figure 1)**

Ref. No.	Part No.	Description	No. Req'd
124	1106 985	Capscrew 1/2 - 13 x 1	4
125	1100 245	Lockwasher 1/2	7
126	1715 428	Wheel Bolt 1/2 - 20	12
127	1714 101	Hitch	1
128	1106 983	Capscrew 1/2 - 13 x 7/8	2
129	1108 847	Square Key 5/16 x 1-1/8	2
130	1107 387	Flat Washer 3/4	5
131	1120 390	Lock Nut 3/4 - 10	2
132	1718 581	Wheel Hub	2
133	1718 599	Frame - L. H.	1
134	1718 596	Frame - R. H.	1
135	1700 401	Extension Spring	1
136	1715 927	End Yoke	1
137	1718 463	Parking Pawl Link	1
138	1104 954	Grease Fitting	2
139	1718 593	Block Bearing	2
140	1708 126	Clevis Pin 3/8 - 13/16	1
141	1104 201	Cotter Pin 3/32 - 5/8	1
142	1106 923	Capscrew 3/8 - 16 x 1-1/4	4
143	1718 485	Shift Pivot Shaft Ass'y	1
144	1106 832	Capscrew 1/4 - 20 x 5/8	4
145	1185 745	Roll Pin 3/16 x 2	1
146	1719 151	Pin	1
147	1718 662	Support Arm	1
148	1719 173	Cylinder Hose Ass'y	1
149	1185 739	Elbow 90°	2
150	1719 145	Cylinder	1
151	1892 435	Idler Tension Spring	1
152	1719 179	Cylinder Hose Ass'y	1
153	1719 152	Pivot Pin	1
154	1103 993	Lockwasher 1/4	2
155	1706 594	Washer	1
156	1721 381	Foot Pedal L. H.	1
157	1718 574	Drag Link	1
158	1104 435	Woodruff Key 1/8 x 5/8	1
159	1719 555	Brake Assembly (Fig. 5)	1
160	1710 348	Pin	1
161	1719 538	Disk Assembly	1
162	1719 006	Fan	1
163	1185 737	Elbow 90°	2
164	1106 919	Capscrew 3/8 - 16 x 1	7
165	1103 514	Set Screw 3/8 - 16 x 1-1/2	2
166		Trans. Assembly (See Figure #3)	1
167	1104 222	Cotter Pin 3/16 x 1-1/2	3
168	1720 527	Interlock Switch	2
169	1721 389	Arm Ass'y (Mod 198-02 only)	1
<b>170 MODEL 18018 - STD. LAWN TIRE KIT</b>			
	1721 431	Wheel and Tire Assy	2
	1717 204	Tire 27 x 8.50 - 15	2
	1721 432	Wheel	2
	1718 242	Valve	2
<b>171 MODEL 18019 - STD. AGR. TIRE KIT</b>			
	1721 440	Wheel and Tire Assy R. H.	1
	1721 441	Wheel and Tire Assy L. H.	1
	1718 243	Tire 27 x 8.50 - 15	2
	1721 432	Wheel	2
	1718 242	Valve	2

Ref. No.	Part No.	Description	No. Req'd
<b>172 MODEL 18016 - TERRA LAWN TIRE KIT</b>			
	1721 434	Wheel and Tire Assy	2
	1719 548	Tire - 26 x 12 - 12	2
	1721 435	Wheel	2
	1718 242	Valve	2
<b>173 MODEL 18017 - TERRA AGR. TIRE KIT</b>			
	1721 437	Wheel and Tire Assy R. H.	1
	1721 438	Wheel and Tire Assy L. H.	1
	1718 298	Tire 26 x 12 - 12	2
	1721 435	Wheel	2
	1718 242	Valve	2
<b>174 MODEL 18020 - DUAL WHEEL KIT</b>			
	1721 428	Wheel and Tire Assy EXT	2
	1718 117	Hub Bolt	12
	1717 204	Tire 27 x 8.50 - 15	2
	1718 242	Valve	2
	1721 429	Extension Wheel	2
<b>175 MODEL 18015 - HI FLOTATION FRONT WHEEL KIT</b>			
	1721 426	Wheel only	2
	*	Tire 20 x 8.00 - 10	2
	1718 086	Valve Component BRGS, ECT, are standard as listed	2
<b>FIGURE 5 - BRAKE ASSEMBLY</b>			
176	1719 557	Actuating Cam	1
177	1719 558	Carrier - Solid Side	1
178	1719 559	Spacer	2
179	1719 560	Puck	2
180	1719 561	Carrier - Cam Side	1
181	1719 562	Washer	1
182	1719 563	Actuator	1
183	1719 564	Washer	1
184	1719 565	Snap Ring	1
185	1719 567	Spring	1
186	1719 568	Bolt 1/4-2	2
187	1100 241	Lockwasher 1/4	2
188	1719 569	Rivet	4
<b>FIGURE 7 - CYLINDER ASSEMBLY</b>			
189	1719 818	Piston Rod Assembly	1
190	1719 819	Butt and Tube Assembly	1
191	1719 820	Gland	1
192	1719 821	Piston	1
193	1719 822	Hex Nut	1
194	1719 823	Snap Ring	1
195	1719 824	O-Ring	2
196	1719 825	Backup Washer	2
197	1719 826	O-Ring	1
198	1719 827	O-Ring	1
199	1719 828	Backup Washer	2
200	1719 829	Wiper	1

\* Obtain from your local Goodyear outlet.

# TRACTOR ASSEMBLY MODEL 198-01 AND 198-02

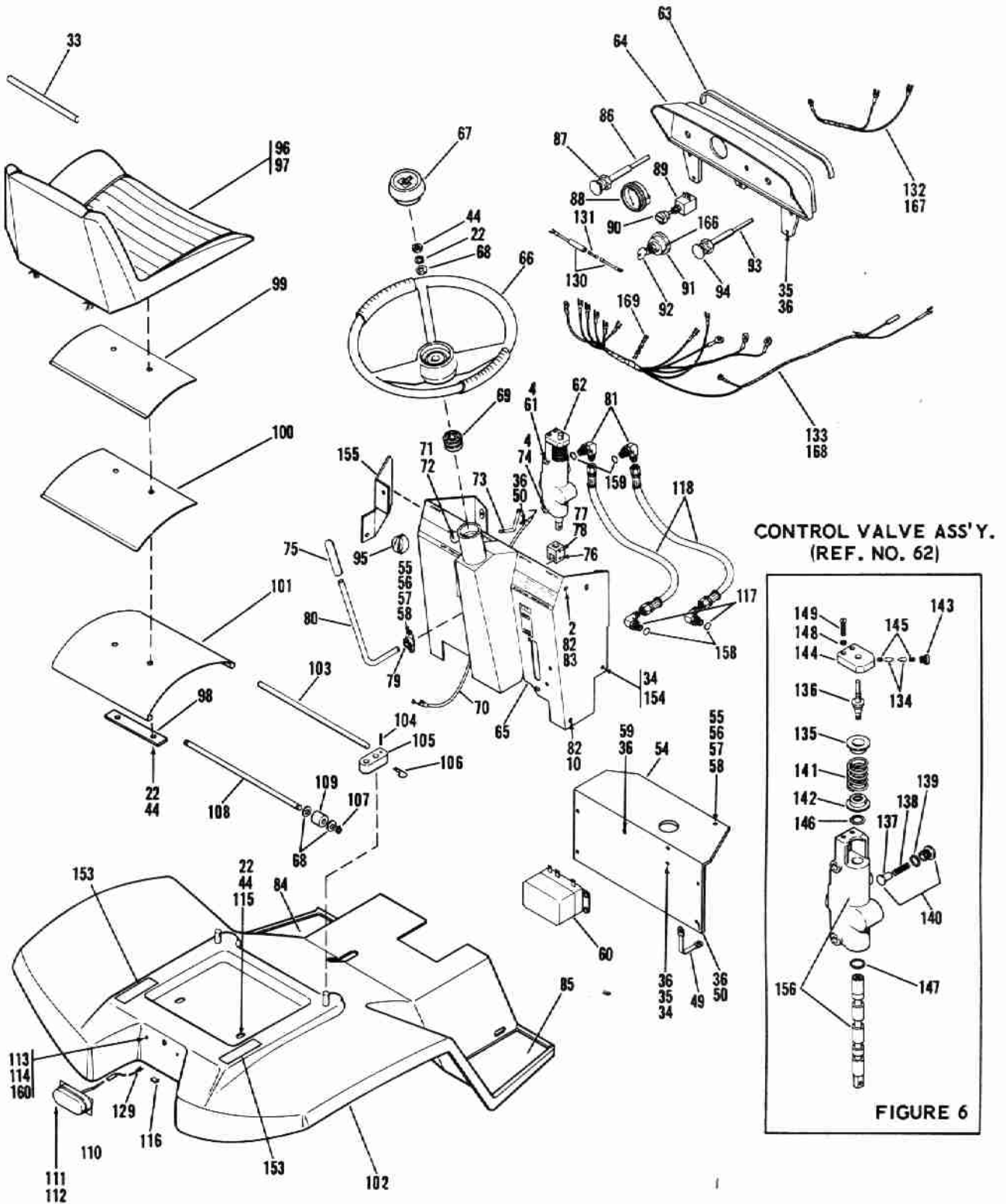

FIGURE 2

# TRACTOR ASSEMBLY MODEL 198-01 AND 198-02

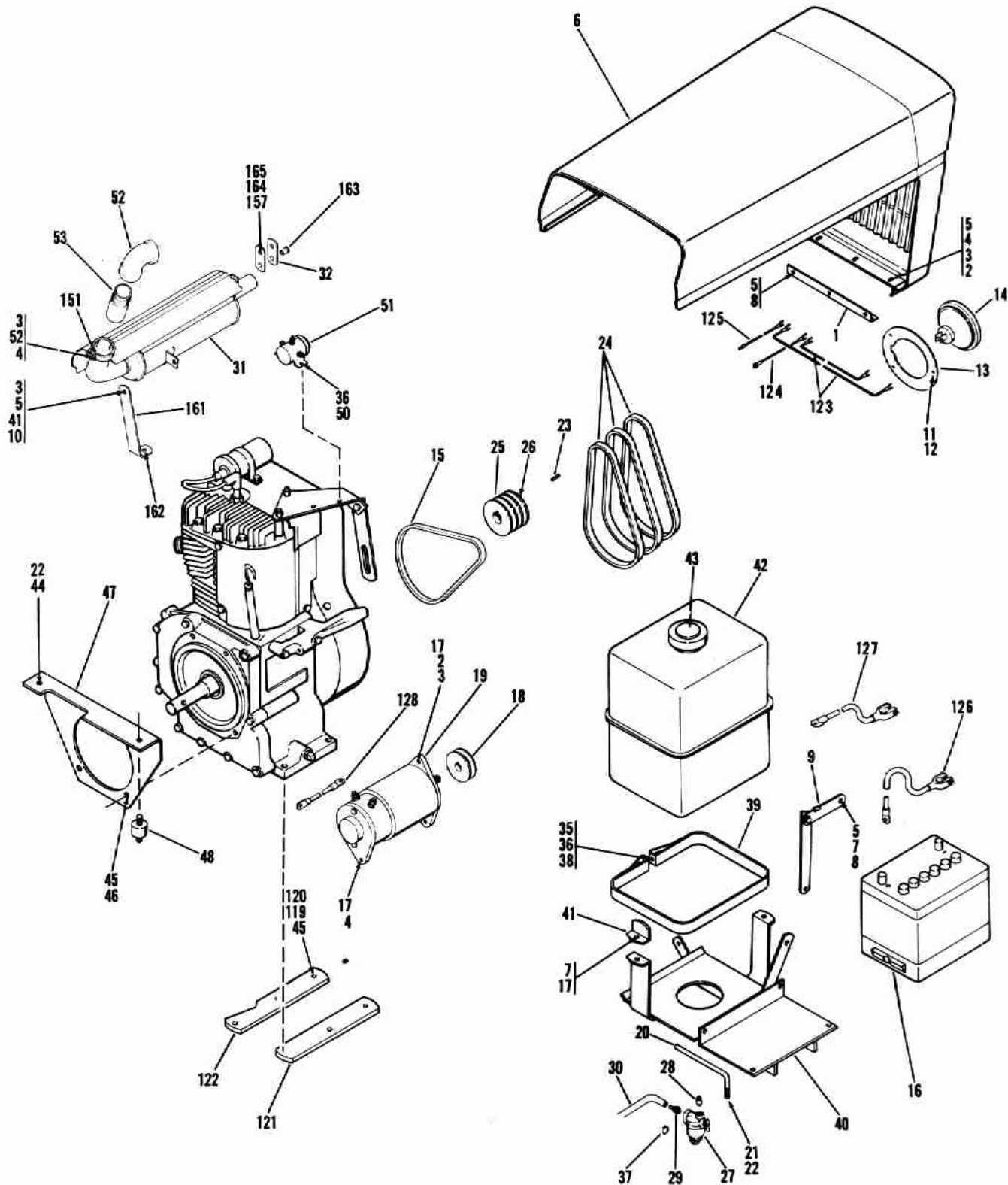

FIGURE 2

**TRACTOR ASSEMBLY MODEL 198-01 AND 198-02**  
(Parts List For Figure 2)

Ref. No.	Part No.	Description	No. Req'd
1	1717 246	Hinge	1
2	1107 362	Flat Washer 5/16	10
3	1182 563	Hex Nut 5/16 - 18	5
4	1100 242	Lockwasher 5/16	10
5	1106 872	Capscrew 5/16 - 18 x 5/8	8
6	1721 497	Grille & Hood Ass'y W/Decals	1
7	1110 107	Lock-Nut 5/16 - 18	4
8	1705 905	Bowed Washer	2
9	1718 500	Hood Stop Assembly	1
10	1103 994	Washer 5/16	2
11	1185 807	Rivet	6
12	1185 746	Spring Clip	6
13	1719 708	Retainer Ring	2
14	*	Headlight Bulb (Mfg. No. 4406)	2
15	1711 844	Gen. Belt 35 5/8" cog.	1
16	1718 027	Battery 12 V - 45 amp	1
17	1106 878	Capscrew 5/16 - 18 x 1	5
18	1719 146	Pulley	1
19	1716 169	Starter Generator	1
20	1718 576	Battery Rod	2
21	1110 024	Wing Nut 3/8 - 16	2
22	1100 243	Lockwasher 3/8	13
23	1108 844	Square Key 1/4 - 1-1/4	1
24	1719 203	Drive Belt 32" (Matched Set of 3)	1
25	1719 198	Drive Sheave	1
26	1103 470	Set Screw 5/16 - 18 x 1/2	2
27	1700 141	Fuel Strainer	1
28	1721 406	Fuel Fitting	1
29	1703 897	Fuel Line Fitting	1
30	1719 204	Fuel Line	1
31	1721 395	Exhaust Muffler	1
32	1721 397	Muffler Hanger	2
33	1720 525	Seat Moulding	1
34	1106 840	Capscrew 1/4 - 20 x 1	4
35	1121 507	Hex Nut 1/4 - 20	13
36	1100 241	Lockwasher 1/4	20
37	1718 185	Hose Clamp	2
38	1114 474	Mach Screw 1/4 - 20 x 1-1/2	1
39	1718 519	Gasoline Tank Strap	1
40	1718 476	Battery & Gas Tank Support	1
41	1718 543	Gas Tank Clip	2
42	1718 600	Gas Tank (Incl 43)	1
43	1718 756	Gas Tank Cap Only	1
44	1121 509	Hex Nut 3/8 - 16	11
45	1100 244	Lockwasher 7/16	8
46	1106 964	Capscrew 7/16 - 14 x 3/4	4
47	1718 603	Engine Face Plate	1
48	1718 542	Engine Mount Rubber	4
49	1719 191	Engine Ground Wire	1
50	1106 830	Capscrew 1/4 - 20 x 1/2	7
51	1717 048	Solenoid	1
52	1100 885	Elbow - 90°	1
53	1721 398	Special Nipple	1
54	1721 372	Heat Shield	1
55	1100 240	Lockwasher #10	4
56	1118 172	Mach Screw 1/4 - 24 x 5/8	4
57	1103 959	Flat Washer #10	4

Ref. No.	Part No.	Description	No. Req'd
58	1109 766	Hex Nut 10-24	4
59	1106 832	Capscrew 1/4 - 20 x 5/8	2
60	1719 181	Voltage Regulator	1
61	1106 893	Capscrew 5/16 - 18 x 2-1/2	1
62	1719 005	Control Valve Ass'y (Fig. 6)	1
63	1717 599	Rubber Pad	1
64	1717 249	Instrument Panel	1
65	1720 548	Steering Column	1
66	1719 164	Steering Wheel	1
67	1719 165	Steering Wheel Cap	1
68	1107 383	Flat Washer 3/8	5
69	1720 134	Self Aligning Bearing	1
70	1719 125	Gauge Control	1
71	1185 726	External Gripping	2
72	1185 727	Tolerance Ring	1
73	1718 608	Gauge Arm	1
74	1106 888	Capscrew 5/16 - 18 x 2	1
75	1718 534	Handle Grip	1
76	1718 537	Valve Adapter	1
77	1120 210	Roll Pin 3/16 x 1	1
78	1104 222	Cotter Pin 3/16 x 1-1/2	3
79	1715 933	Pillow Block	1
80	1718 538	Control Lever Hydraulic	1
81	1185 737	Elbow - 90°	2
82	1106 870	Capscrew 5/16 - 18 x 1/2	4
83	1185 725	Centerlock Nut 5/16 - 18	2
84	1719 182	Foot Pad - L. H.	1
85	1719 183	Foot Pad - R. H.	1
86	1718 607	Choke Control (Incl 87)	1
87	1718 232	Choke Knob-Wire Only	1
88	1714 146	Ammeter	1
89	1717 256	Light Switch (Incl 90)	1
90	1718 231	Light Switch Knob Only	1
91	1719 143	Ignition Switch (Incl 92) (191-01 Only)	1
92	1718 266	Key Only	1
93	1717 590	Throttle Control (Incl 94)	1
94	1718 233	Throttle Knob & Wire Only	1
95	1719 004	Knob	1
96	1717 352	Seat Pan Assembly	1
97	1721 399	Seat Pad	1
98	1718 552	Mounting Strap	1
99	1718 530	Leaf Spring	1
100	1718 511	Leaf Spring	1
101	1718 510	Leaf Spring	1
102	1721 382	Rear Fender	1
103	1718 560	Pivot Pin	1
104	1177 625	Roll - Pin 1/8 x 3/4	2
105	1719 206	Adjusting Block	2
106	1703 011	Spring Cotter	2
107	1118 799	Retaining Ring	2
108	1718 566	Roller Shaft	1
109	1718 562	Roller	2
110	1805 342	Tailight Assembly (Incl No. 111 & 112)	1
111	*	Bulb (Mfg. No. 1895)	1
112	1805 110	Lens Only	1
113	1116 197	Mach Screw #6 - 32 x 1/2	2
114	1109 764	Hex Nut 6-32	2
115	1106 917	Capscrew 3/8 - 16 x 7/8	4
116	1717 854	Wire Clamp	3

\* Not Stocked. Purchase from your local automotive or electrical supplier.



**TRACTOR ASSEMBLY MODEL 198-01 AND 198-02**  
**(Parts List For Figure 2)**

Ref. No.	Part No.	Description	No. Req'd
117	1185 738	Elbow - 90°	2
118	1719 177	Trans. Hose Assembly	2
119	1107 013	Capscrew 7/16 - 14 x 1-3/4	4
120	1110 109	Lock-Nut 7/16 - 14	4
121	1718 523	Engine Support	1
122	1718 579	Engine Support	1
123	1717 370	Lead Assembly	2
124	1717 394	Lead Assembly	1
125	1717 369	Lead Assembly	1
126	1719 189	Ground Wire	1
127	1719 190	Positive Wire	1
128	1719 192	Starter Wire	1
129	1720 544	Wiring Harness (See Page 11) (Mod 198-01 Only)	1
130	1719 193	Fuse Holder (Mod 198-01 Only)	1
131	1719 194	Fuse (Mod 198-01 Only)	1
132	1719 186	Wiring Assembly (Mod 198-01 Only)	1
133	1720 545	Wiring Harness (See Page 11) (Mod 198-01 Only)	1
134	1719 472	Detent Pawl	2
135	1719 473	Shallow Washer	1
136	1719 474	Detent Float Screw	1
137	1719 475	Lift Check Plunger	1
138	1719 476	Lift Check Spring	1
139	1719 461	O-Ring 3/32 x 1/2 I.D.	1
140	1719 477	Lift Check Plug Ass'y (Inc Ref 137-138-139)	1
141	1719 478	Spool Center Spring	1
142	1719 480	Deep Washer	1
143	1719 482	Detent Pawl Plug	1

Ref. No.	Part No.	Description	No. Req'd
144	1719 483	Detent Block	1
145	1719 484	Dent Pawl Spring	2
146	1719 485	O-Ring 3/32 x 5/8 I.D.	1
147	1719 486	O-Ring 1/8 x 5/8 I.D.	1
148	1100 241	Lockwasher 114	2
149	1100 122	Mach Screw 1/4 x 20 x 1	2
150	1719 487	Seal Repair Kit (Incl 139, 146 & 147)	1
151	1721 534	Clamp Assy (Inc Ref 3-4- 152)	1
152	1111 267	Carr Bolt 5/16-18 x 1-1/4	1
153	1721 369	Wear Strip	2
154	1103 993	Washer, Lock Ext 1/4	2
155	1719 744	Heat Shield	1
156		Not sold separately, re- place with complete control valve assy.	1
157	1110 106	Lock Nut 1/4 x 20	2
158	1185 773	O-Ring	2
159	1185 835	O-Ring	2
160	1103 989	Shakeproof Lockwasher #6	2
161	1721 396	Muffler Bracket	1
162	1110 108	Lock Nut 3/8 x 16	2
163	1185 805	Flange Brg.	2
164	1705 119	Bowed Washer	4
165	1106 837	Capscrew 1/4-20 x 7/8	2
166	1721 409	Ignition Switch (198-02 Only)	1
167	1721 465	Wiring Harness (198-02 Only)	1
168	1721 466	Wiring Harness (198-02 Only)	1
169	1719 496	Wire Tie	1

# TRANSAXLE ASSEMBLY MODEL 197

(Parts List For Figure 3 on Page 11)

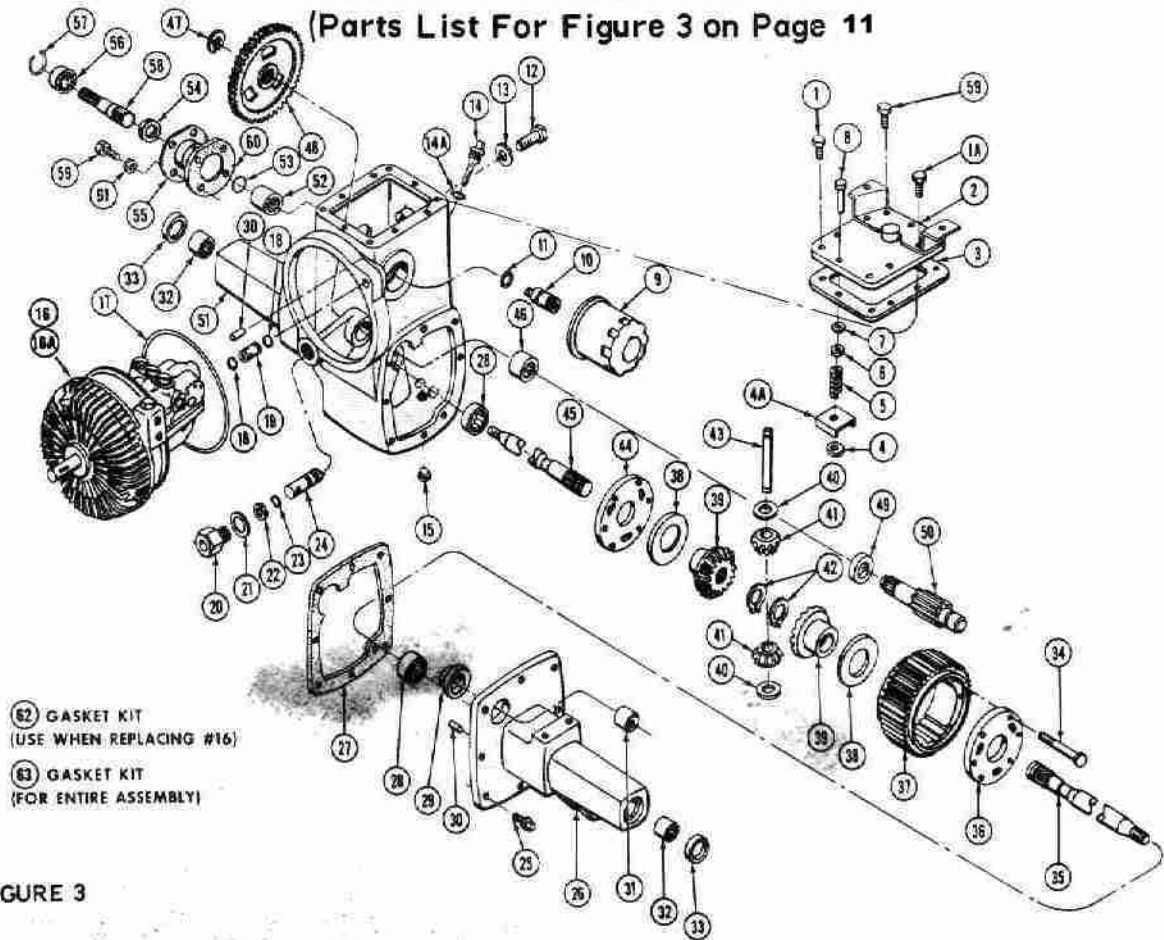

FIGURE 3

**TRACTOR ASSEMBLY MODEL 198-01 AND 198-02**  
**(Parts List For Figure 3)**

Ref. No.	Part No.	Description	No. Req'd
1	1720 308	Capscrew 1/4-20 UNC x 5/8	3
1A	1720 287	Capscrew 1/4-20 UNC x 3/4	2
2	1719 851	Cover Service Kit (includes 1A # 2 and 4)	1
3	1719 852	Gasket (Transmission Cover)	1
4	1719 853	Speed Nut	1
4A	1719 854	Deflector	1
5	1719 855	Spring	1
6	1719 855	Washer	1
7	1719 857	Gasket (Button Ass'y)	1
8	1719 858	Button Sub-Assembly	1
9	1719 859	Oil Filter	1
10	1719 860	Filter Stud	1
11	1720 309	O-Ring (Filter Stud)	1
12	1719 861	Capscrew 1/2-13 UNC x 2-1/2	1
13	1719 862	Seal Washer (Mounting Bolt)	1
14	1719 863	Dipstick	1
14A	1720 310	O-Ring (Dipstick)	1
15	1720 311	Drain Plug 1/4-18 NPTF	1
*16	1719 894	Hydro Pkg (198-01 Only)	1
*16A	1721 535	Hydro Pkg (198-02 Only)	1
17	1719 865	O-Ring (Transmission Housing)	1
18	1719 866	O-Ring (Connecting Tube)	2
19	1719 867	Tube-Connecting	1
20	1719 868	Bushing (Parking Pawl)	1
21	1719 869	Sealing Washer (Parking Pawl)	1
22	1719 870	Quad-Ring (Parking Pawl)	1
23	1720 312	O-Ring (Parking Pawl)	1
24	1719 871	Parking Pawl	1
25	1719 872	Capscrew 3/8-16 UNC x 1-1/4 Special	3
26	1719 873	Axle Housing	1
27	1719 874	Gasket (Housing)	1
28	1720 313	Needle Bearing	2
29	1719 875	Spacer	1
30	1719 876	Dowel 5/16 x 3/4	2
31	1720 314	Needle Bearing (Closed End)	1
32	1720 315	Needle Bearing	2

Ref. No.	Part No.	Description	No. Req'd
33	1719 877	Oil Seal (Axles)	2
34	1720 316	Capscrew 3/16-16 UNC x 3-1/2	6
35	1719 878	Axle (Left Hand)	1
36	1719 879	Cover (Left Hand)	1
37	1719 880	Ring Gear	1
38	1719 881	Shim .500	AR
38	1720 307	Shim .010	AR
39	1719 882	Side Gear (Differential)	2
40	1719 883	Thrust Washer	2
41	1719 884	Pinion Gear (Differential)	2
42	1720 317	Retaining Ring	2
43	1719 885	Shaft	1
44	1719 886	Cover (Right Hand)	1
45	1719 887	Axle (Right Hand)	1
46	1720 318	Needle Bearing	1
47	1720 319	Bowed "E" Ring	1
48	1719 888	Bull Gear	1
49	1719 889	Spacer	1
50	1719 890	Intermediate Gear	1
51	1719 891	Transmission Housing Sub-Assembly	1
52	1719 892	Coupling	1
53	1719 893	Snap Ring (Brake Shaft)	1
54	1719 894	Oil Seal (Brake)	1
55	1719 895	Flange Bearing Adapter	1
56	1720 320	Ball Bearing	1
57	1719 896	Snap Ring (Bearing)	1
58	1719 897	Brake Shaft	1
59	1720 321	Capscrew 5/16-18 UNC x 3/4	7
60	1719 898	Gasket (Brake Flange)	1
61	1719 899	Sealing Washer (Brake Bolts)	4
62	1720 288	Gasket Kit (Use when replacing #16) (Includes # 3, 11, 13, 17, 18, 80, 61)	1
63	1720 289	Gasket Kit (For entire assembly) (Includes # 14A, 21, 22, 23, 27, 62)	1
	1719 650	Hydrostatic Fluid, 1 gal	
	1721 514	Hydrostatic Fluid, 2-1/2 gal	

\* Available only as a complete package

**Parts List For Wiring Diagram Figures 4 and 5**

Ref. No.	Part No.	Description	No. Req'd
1	**	Headlight Bulb (Mfg No. 4406)	2
2	1719 706	Retainer Ring	2
3	1185 680	Phillips Screw 10-32 x 3/4	6
4	1100 240	Lockwasher #10	6
5	1109 845	Hex Nut #10-32	6
6	1717 370	Lead Assembly	2
7	1717 394	Lead Assembly	1
8	1717 369	Lead Assembly	1
9	1719 189	Ground Wire	1
10	1719 190	Positive Wire	1
11	1719 192	Starter Wire	1
12	1720 527	Interlock Switch	2
13	1719 193	Fuse Holder (198-01 Only)	1
14	1719 194	Fuse 14 AMP (198-01 Only)	1
15	1719 186	Wiring Assembly (198-01 Only)	1
16	1718 027	Battery	1

Ref. No.	Part No.	Description	No. Req'd
17	1716 169	Starter Generator	1
18	1717 048	Solenoid	1
19	1719 181	Voltage Regulator	1
20	1719 143	Ignition Switch (198-01 Only)	1
21	1717 256	Light Switch	1
22	1714 146	Ammeter	1
23	1805 342	Taillight Assembly (Incl. Ref. No. 24 & 25)	1
24	**	Bulb (Mfg No. 1895)	1
25	1805 110	Lens Only	1
26	1115 197	Mach. Screw 6-32 x 1/2	2
27	1103 989	Lockwasher #6	2
28	1109 764	Hex Nut #6-32	2
29	1720 977	Fuse Holder (198-02 Only)	1
30	1720 976	Fuse 20 AMP (198-02 Only)	1
31	1721 409	Ignition Switch (198-02 Only)	1

\*\* Not Stocked. Purchase from your local automotive or electrical supplier.

# DUAL LIGHT GROUP WIRING DIAGRAM

NOTE:

WIRES DESIGNATED BY COLOR ONLY ARE CONTAINED IN WIRING HARNESS PART NO. 1720545

NOTE:

WIRES DESIGNATED BY COLOR WITH AN ASTERISK (\*) ARE CONTAINED IN WIRING HARNESS PART NO. 1720544

