

# BOLENS

---

**HUSKY**  
**TRACTOR**  
**MODEL 1257 - 01**

## ILLUSTRATED PARTS CATALOG



# BOLENS

PORT WASHINGTON, WISCONSIN, U.S.A.

PRINTED IN U.S.A.

FORM NO. P-552091  
3/70

# TRACTOR ASSEMBLY MODEL 1257-01

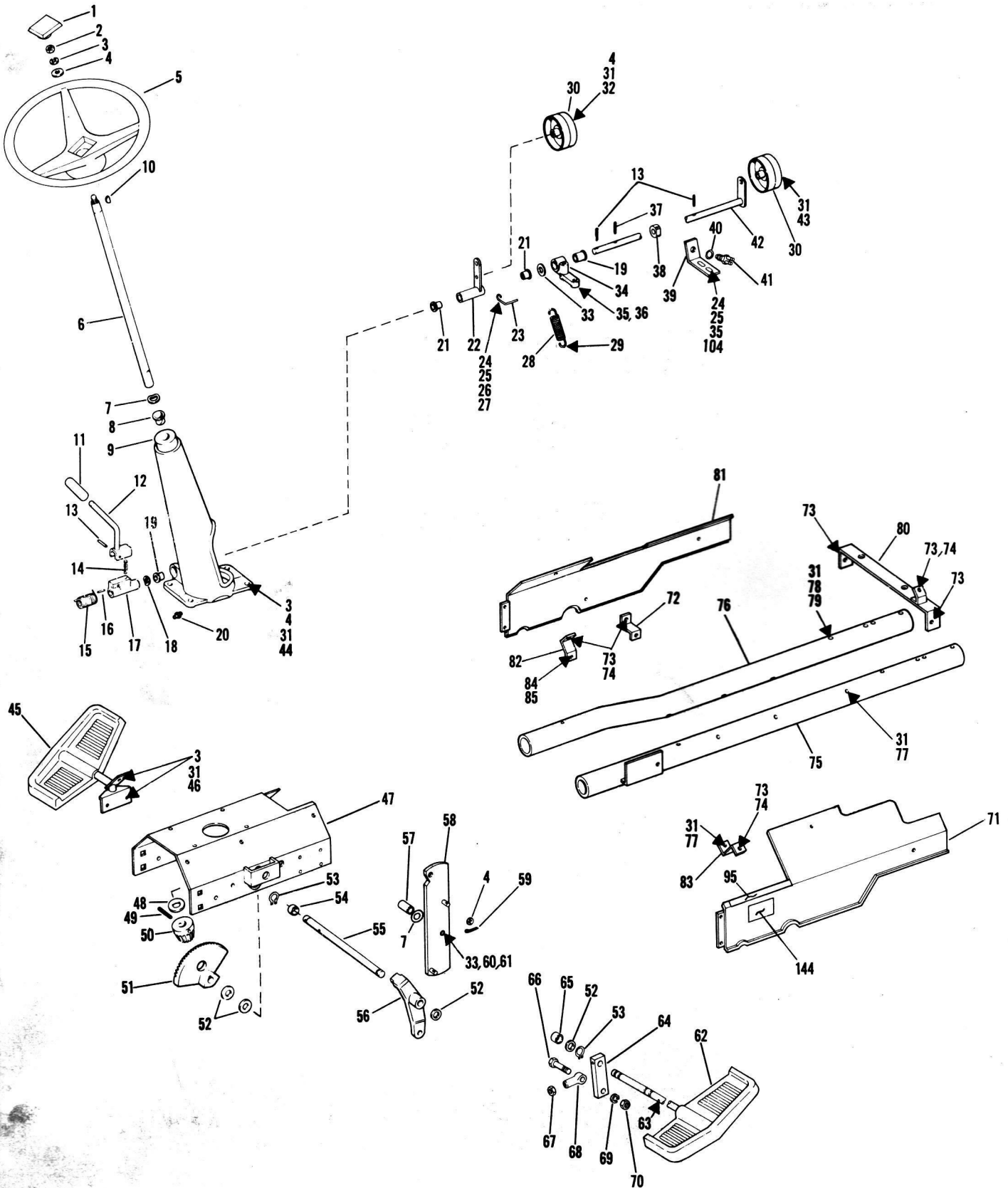

FIGURE 1

# TRACTOR ASSEMBLY MODEL 1257-01

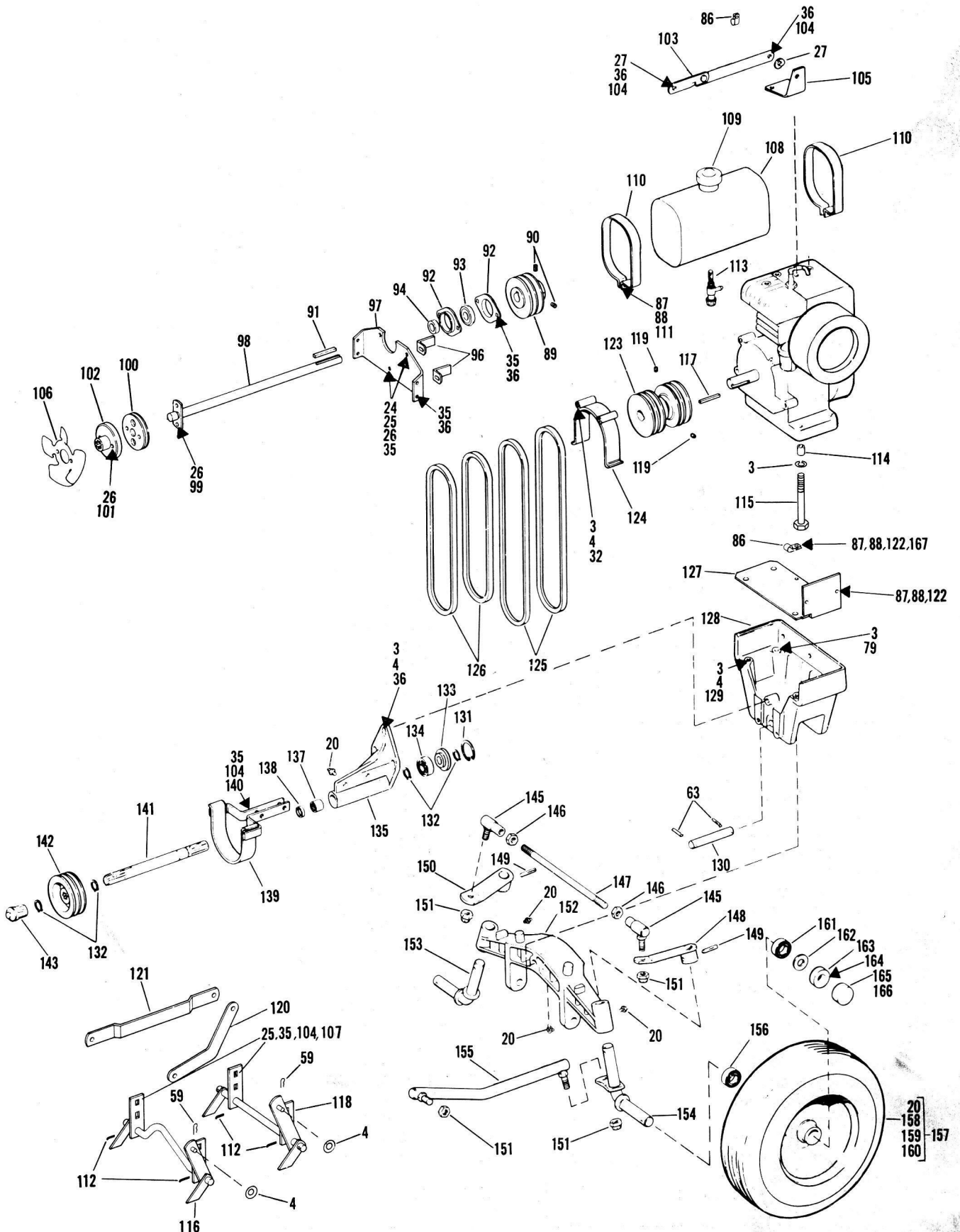

FIGURE 1

# TRACTOR ASSEMBLY MODEL 1257-01

## FIGURE 1 PARTS LIST

Ref. No.	Part No.	Description	No. Req'd
1	1721 804	Cap	1
2	1121 509	Hex Nut 3/8-16	1
3	1100 243	Lockwasher 3/8	20
4	1107 383	Flat Washer 3/8	17
5	1721 805	Steering Wheel	1
6	1717 269	Steering Shaft	1
7	1713 122	Bowed Washer	2
8	1717 263	Bearing	1
9	1717 258	Steering Support	1
10	1104 436	Woodruff Key 3/16 x 3/4	1
11	1721 896	Grip	1
12	1721 927	PTO Control Lever	1
13	1704 692	Roll Pin 1/8 x 1	3
14	1713 391	Spring	1
15	1715 680	Spring	1
16	1120 210	Roll Pin 3/16 x 1	1
17	1715 679	PTO Pivot (Inc 16)	1
18	1706 782	Bowed Washer	1
19	1185 647	Bearing	2
20	1104 954	Grease Fitting	6
21	1715 538	Flanged Bushing	2
22	1720 436	Idler Arm	1
23	1720 717	Belt Guide	1
24	1107 382	Flat Washer 5/16	5
25	1106 876	Capscrew 5/16-18 x 7/8	13
26	1110 107	Lock Nut 5/16-18	7
27	1705 905	Bowed Washer	3
28	1716 728	Spring	1
29	1185 584	Cotter Pin 3/16 x 3/4	1
30	1716 584	Idler Pulley	2
31	1110 108	Lock Nut 3/8	15
32	1106 936	Capscrew 3/8-16 x 2-1/2	3
33	1107 385	Flat Washer 1/2	2
34	1716 590	Shaft Support	1
35	1100 242	Lockwasher 5/16	18
36	1106 872	Capscrew 5/16-18 x 5/8	6
37	1185 892	Drive Pin 1/8 x 1	1
38	1720 962	Interlocking Switch Cam	1
39	1720 533	Switch Support	1
40	1185 844	Shakeproof Washer 9/16	1
41	1720 963	Interlock Switch	1
42	1716 615	Control Shaft	1
43	1106 930	Capscrew 3/8-16 x 1-3/4	1
44	1106 923	Capscrew 3/8-16 x 1-1/4	4
45	1721 930	LH Pedal	1
46	1106 917	Capscrew 3/8-16 x 7/8	2
47	1720 439	Mounting Plate	1
48	1708 012	Flat Washer	1
49	1185 284	Drive Pin 1/4 x 2	1
50	1713 811	Steering Pinion	1
51	1713 809	Steering Gear	1
52	1705 092	Washer	3
53	1185 668	Retaining Ring	3
54	1185 558	Sleeve Bearing	2
55	1721 932	Cross Shaft	1
56	1716 563	Steering Arm	1
57	1720 610	Sleeve	1
58	1720 729	Tool Lift Lever	1
59	1703 011	Cotter Spring	3
60	1185 496	Lock Nut 1/2-13	1
61	1107 035	Capscrew 1/2-13 x 2	1
62	1721 933	RH Pedal	1

Ref. No.	Part No.	Description	No. Req'd
63	1185 232	Drive Pin 3/16 x 1-1/4	3
64	1720 565	Control Arm	1
65	1714 233	Nylon Bushing	2
66	1107 013	Capscrew 7/16-14 x 1-3/4	1
67	1121 710	Jam Nut	1
68	1721 612	Rod End	1
69	1100 244	Lockwasher 7/16	1
70	1110 109	Lock Nut 7/16-14	1
71	1722 129	Side Panel RH	1
72	1721 912	Side Panel Support LH Fr	1
73	1185 872	Screw 5/16-18 x 5/8	6
74	1185 873	Tinnerman Nut 5/16-18	4
75	1721 895	Frame Tube RH	1
76	1720 341	Frame Tube LH	1
77	1106 938	Capscrew 3/8-16 x 2-3/4	5
78	1185 506	Jam Nut 3/8-16	1
79	1111 614	Capscrew 3/8-16 x 3 HT	3
80	1722 125	Panel Support	1
81	1722 130	Side Panel LH	1
82	1721 910	Side Panel Support LH Rear	1
83	1721 911	Side Panel Support RH	1
84	1115 931	Screw 1/4-20 x 5/8	1
85	1185 456	Tinnerman Nut	1
86	1721 037	Cable Clip	2
87	1100 241	Lockwasher 1/4	5
88	1110 106	Lock Nut 1/4-20	5
89	1720 365	Driven Pulley	1
90	1103 494	Set Screw 3/8-16 x 1/2	2
91	1104 335	Sq Key 3/16 x 2	1
92	1185 838	Brg Flange	2
93	1800 757	Ball Bearing	1
94	1800 417	Brg. Collar	1
95	1721 890	Decal (Lift Indicator)	1
96	1720 437	Belt Guide	2
97	1720 438	Bearing Support	1
98	1720 455	Drive Shaft	1
99	1110 818	Soc Hd Scr 5/16-18 x 3/4	2
100	1716 561	Bonded Coupling	1
101	1185 826	Soc Hd Scr 5/16-18 x 1	2
102	1720 348	Shaft Coupling	1
103	1717 236	Hood Stop	1
104	1182 563	Hex Nut 5/16-18	14
105	1722 153	Bracket	1
106	1720 349	Fan	1
107	1100 255	Flat Washer 5/16	8
108	1714 767	Tank (Inc 109)	1
109	1714 766	Cap Only	1
110	1714 685	Tank Strap	1
111	1114 474	Fil. Screw 1/4-20 x 1-1/2	2
112	1100 350	Cotter Pin 1/8 x 1	4
113	1718 029	Tank Outlet	1
114	1714 648	Spacer	4
115	1111 615	Capscrew 3/8-16 x 3-1/2 HT	4
116	1720 493	Lift Arm (Rear)	1
117	1187 474	Sq. Key 1/4 x 2-1/4	1
118	1720 492	Lift Arm (Front)	1
119	1103 470	Set Screw 5/16-18 x 1/2	2
120	1722 454	Control Link	1
121	1722 455	Link	1
122	1115 935	Phil Screw 1/4-20 x 3/4	3
123	1722 173	Engine Pulley	1
124	1716 642	Belt Guide	2

# TRACTOR ASSEMBLY MODEL 1257-01

## FIGURE 1 PARTS LIST CONTINUED

Ref. No.	Part No.	Description	No. Req'd
125	1716 570	Belt 42-1/2' Set of 2 (PTO)	1
126	1720 573	Belt 34" Set of 2 (Eng Dr)	1
127	1722 101	Plate	1
128	1717 270	Axle Support	1
129	1110 644	Capscrew 3/8-16 x 3-1/4	2
130	1713 383	Axle Pivot	1
131	1118 730	Retaining Ring	1
132	1185 649	Retaining Ring	4
133	1721 590	Seal Washer	1
134	1185 605	Ball Bearing	1
135	1715 785	Support Housing	1
136	1106 921	Capscrew 3/8-16 x 1-1/8	3
137	1185 010	Needle Bearing	1
138	1185 224	Oil Seal	1
139	1716 647	Belt Guide	1
140	1106 880	Capscrew 5/16-18 x 1-1/8	2
141	1721 597	Shaft and Seal PTO (Inc 133)	1
142	1716 594	Pulley PTO	1
143	1714 132	Rubber Tip	2
144	1721 653	Decal (Hydrostatic Drive)	2
145	1713 361	Ball Joint	2
146	1103 926	Jam Nut 1/2-20	2

Ref. No.	Part No.	Description	No. Req'd
147	1713 385	Tie Rod	1
148	1713 378	Steering Lever RH	1
149	1891 696	Drive Pin 5/16 x 1-1/2	2
150	1713 377	Steering Lever LH	1
151	1110 152	Self Locking Nut 1/2-20	4
152	1716 697	Axle	1
153	1716 953	Spindle LH	1
154	1716 952	Spindle RH	1
155	1717 462	Drag Link	1
156	1185 616	Ball Bearing	2
157	1717 357	Wheel and Tire (20, 156-161)	2
158	1715 855	Valve Stem Assembly	2
159	1715 789	Wheel Only (Inc Ref 20)	2
160	1717 441	Tire 16 x 6:50 x 8	2
161	1185 615	Ball Bearing	2
162	121 898	Washer	4
163	1716 197	Set Collar	2
164	1187 857	Capscrew 1/4-20 x 1	2
165	1715 899	Dust Cap 1-1/2 ID (Some Mod)	2
166	1721 245	Dust Cap 1-5/8 ID (Some Mod)	2
167	1107 381	Flat Washer 1/4	1

## ELECTRICAL GROUP AND COMPONENT PARTS (For wiring diagram see page 12)

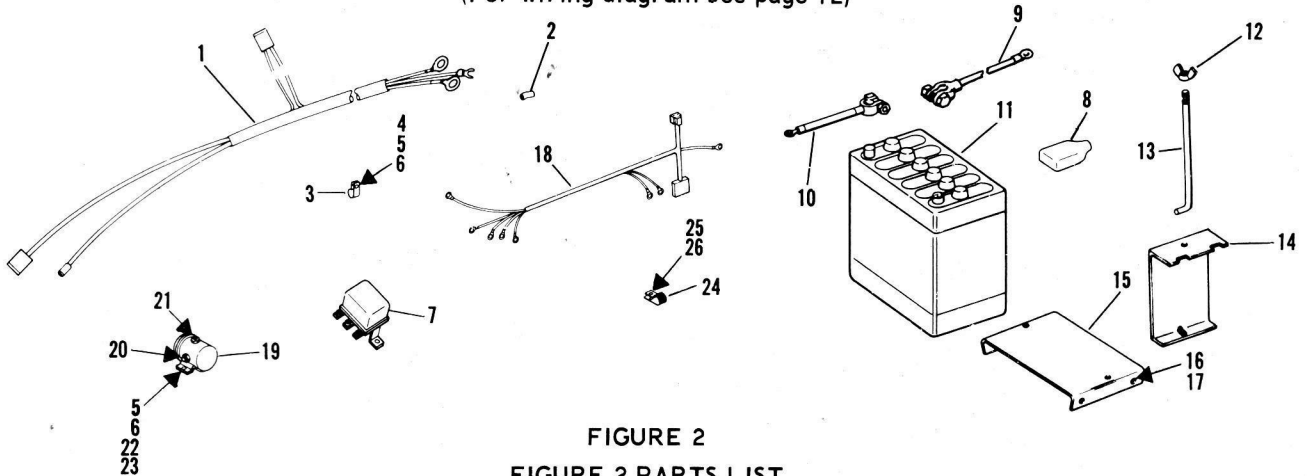

## FIGURE 2 FIGURE 2 PARTS LIST

Ref. No.	Part No.	Description	No. Req'd
1	1722 131	Interlock & Tail Light Wire Harness	1
2	1721 038	Connector	1
3	1721 037	Clip	2
4	1115 931	Mach Screw 1/4-20 x 5/8	2
5	1110 106	Lock Nut 1/4-20	3
6	1100 241	Lockwasher 1/4	4
7	*	Rectifier Regulator	1
8	1721 413	Batt Terminal Boot	1
9	1722 108	Batt Lead (Positive)	1
10	1716 636	Batt Lead (Ground)	1
11	1718 027	Battery 12V 45AMP	1
12	1709 652	Wing Nut 1/4-20	2
13	1718 108	Batt Clamp Rod	2

Ref. No.	Part No.	Description	No. Req'd
14	1720 538	Batt Clamp	2
15	1718 111	Batt Carrier	1
16	1185 872	Truss HD Scr 5/16-18 x 5/8	4
17	1185 873	Tinnerman Nut 5/16-18	4
18	1722 062	Wiring Harness	1
19	1717 048	Solenoid	1
20	1182 563	Hex Nut 5/16-18	2
21	1109 845	Hex Nut #10-32	1
22	1100 118	Mach Screw 1/4-20 x 1/2	2
23	1107 381	Flat Washer 1/4	2
24	1704 930	Clamp - Vinyl Coated	1
25	1100 242	Lock Washer 5/16	1
26	1106 872	Capscrew 5/16-18 x 5/8	1

\*Not stocked. Purchase from your local Tecumseh Products Co., Lauson-Power Products Parts Outlet.

# TRACTOR ASSEMBLY MODEL 1257-01

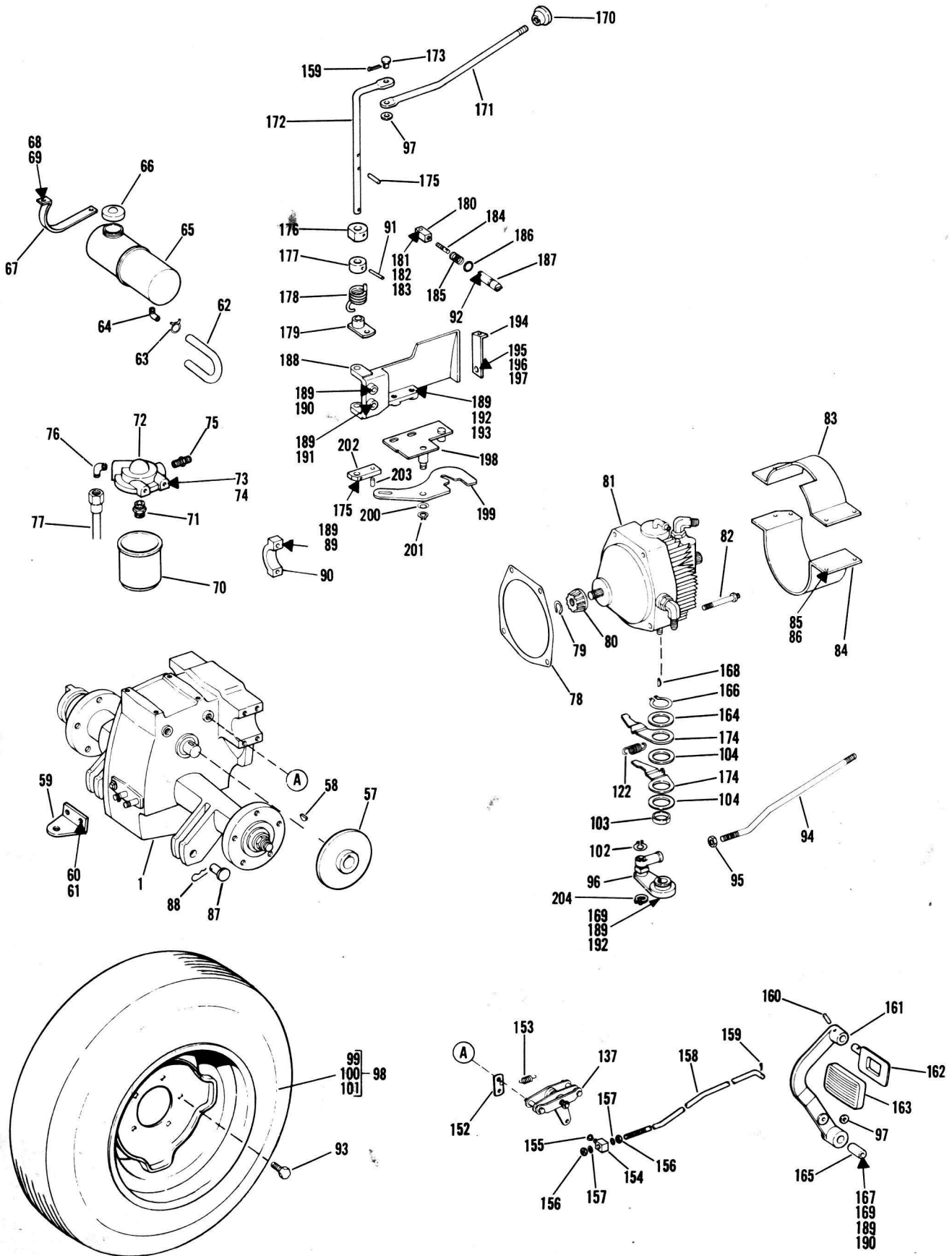

FIGURE 3

# TRACTOR ASSEMBLY MODEL 1257-01

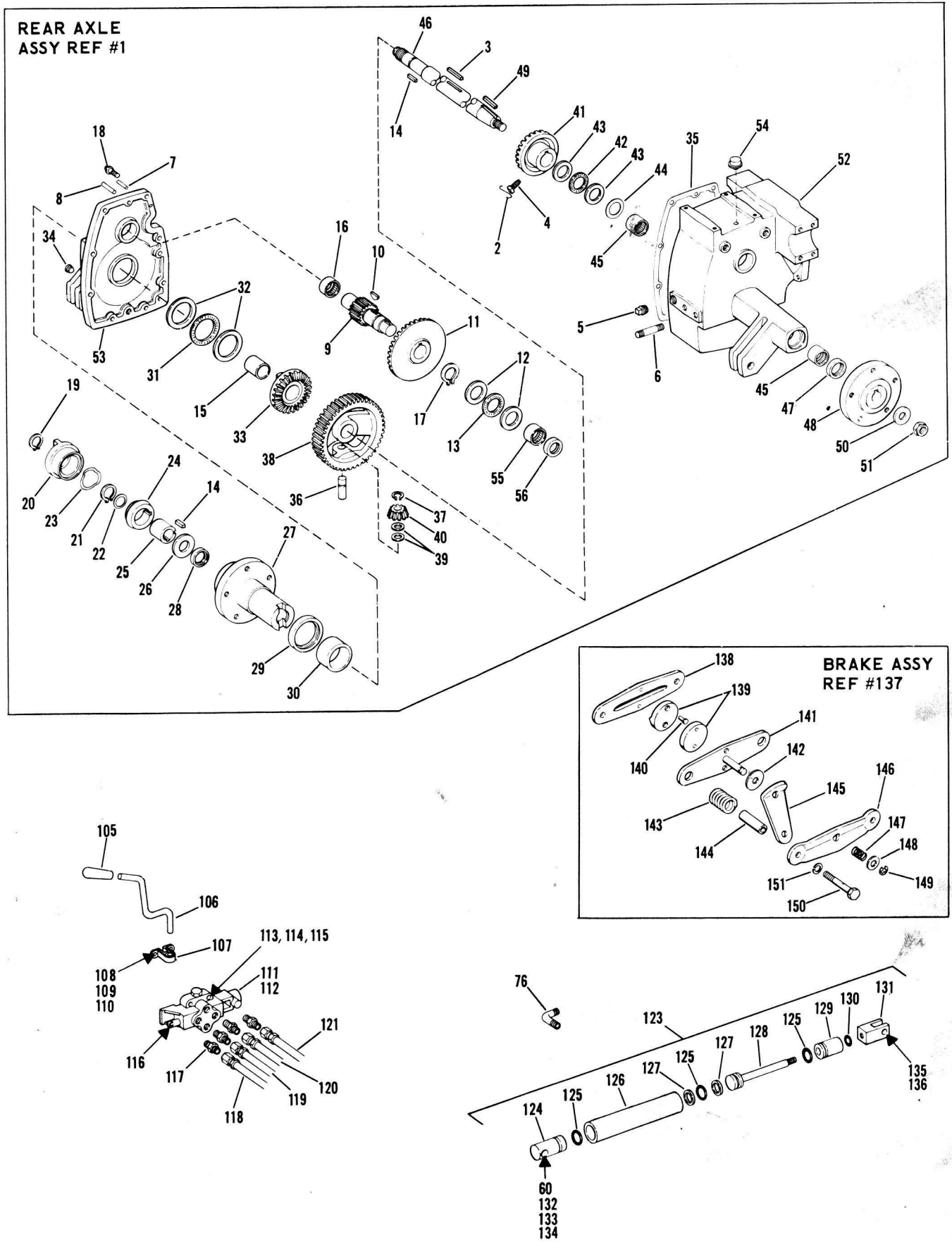

FIGURE 3

# TRACTOR ASSEMBLY MODEL 1257-01

## FIGURE 3 PARTS LIST

Ref. No.	Part No.	Description	No. Req'd
1	1722 476	Rear Axle Assy (Inc Ref 2-56) See page 6 for Illust.	1
2	1716 692	Locking Wire	1
3	1721 587	Key 1/4 Sq x 1-1/4	1
4	1716 519	Drive Screw	2
5	1105 678	Pipe Plug 3/8	1
6	1718 067	Stud	2
7	1185 232	Roll Pin 3/16 x 1-1/4	1
8	1110 187	Dowel Pin 5/16 x 1	2
9	1722 137	Pinion Shaft	1
10	1100 279	Woodruff Key 1/4 x 1	1
11	1720 259	Bevel Gear	1
12	1185 767	Thrust Race	2
13	1185 764	Thrust Bearing	1
14	1104 336	Key 1/4 Sq x 1	2
15	1185 832	Bearing	1
16	1185 774	Needle Bearing	1
17	1185 303	Retaining Ring	1
18	1185 771	Ferry Screw 3/8-16 x 1	7
19	1180 025	Retaining Ring	1
20	1714 564	Adjusting Nut	1
21	1185 689	Retaining Ring	1
22	1800 338	Shim	AR
23	1721 357	Spring Washer	2
24	1714 562	Cone	1
25	1714 561	Coupling	1
26	1713 468	Thrust Washer	1
27	1720 266	LH Wheel Hub	1
28	1185 295	Oil Seal	1
29	1185 769	Oil Seal	1
30	1185 770	Bearing	1
31	1185 768	Thrust Bearing	1
32	1185 765	Thrust Race	2
33	1720 264	Bevel Gear	1
34	1105 640	Countersunk Pipe Plug	1
35	1720 257	Gasket	1
36	1713 467	Differential Pinion Shaft	2
37	1185 561	Retaining Ring	2
38	1720 268	Gear and Carrier	1
39	1712 763	Thrust Washer	4
40	1713 466	Bevel Pinion	2
41	1720 271	Bevel Gear	1
42	1185 763	Thrust Bearing	1
43	1185 766	Thrust Race	2
44	1720 299	Shim	AR
45	1185 645	Needle Bearing	2
46	1720 269	Axle	1
47	1185 642	Oil Seal	1
48	1720 293	Wheel Hub	1
49	1108 848	Key 5/16 Sq x 1-1/4	1
50	1185 847	Special Flat Washer	1
51	1110 297	Lock Nut 5/8-18	1
52	1722 136	Gear Case Housing	1
53	1720 252	Cover	1
54	1826 82	Breather	1
55	1185 088	Needle Bearing	1
56	1185 882	Oil Seal	1
57	1722 159	Brake Disc	1
58	1200 034	Hi Pro Key 1/4 x 7/8	1
59	1714 101	Hitch	1
60	1110 110	Lock Nut 1/2-13	3
61	1100 245	Lock Washer 1/2	2

Ref. No.	Part No.	Description	No. Req'd
62	1720 947	Oil Line Hose	1
63	1185 820	Clamp	2
64	1703 897	Elbow	1
65	1721 900	Oil Reservoir Tank	1
66	1721 901	Tank Cap	1
67	1721 902	Tank Strap	2
68	1115 931	Screw 1/4-20 x 5/8	4
69	1185 456	Tinnerman Nut	4
70	1719 859	Oil Filter	1
71	1721 921	Special Coupling	1
72	1721 920	Filter Manifold	1
73	1100 242	Lock Washer 5/16	11
74	1106 874	Cap Screw 5/16-18 x 3/4	2
75	1721 989	Connector	1
76	1185 739	Elbow 90°	3
77	1721 922	Tube - (Filter Outflow to Hydro.)	1
78	1720 282	Motor Gasket	1
79	1118 808	Retaining Ring	1
80	1720 285	Bevel Pinion	1
81	1722 180	Hydrostatic Pkg. (Inc Ref 78)	1
82	1185 775	Capscrew (Spec)	4
83	1720 957	Fan Guard Top	1
84	1720 688	Fan Guard Bottom	1
85	1187 612	Lock Washer 1/4	4
86	1185 375	Cutting Screw 1/4-20 x 3/4	4
87	1719 367	Clevis Pin	2
88	1703 011	Cotter Pin	2
89	1106 930	Capscrew 3/8-16 x 1-3/4	8
90	1713 461	Mounting Cap	4
91	1185 314	Drive Pin 1/8 x 1-1/4	1
92	1187 961	Roll Pin 5/32 x 1	1
93	1010 85	Hub Bolt	10
94	1720 716	Control Rod	1
95	1121 710	Jam Nut	1
96	1722 228	Speed Control Arm Assy	1
97	1107 382	Flat Washer 5/16	2
98	1715 866	Wheel & Tire Assy (99-101)	2
99	1715 787	Wheel Only	2
100	1715 856	Tubeless Tire 8 x 12	2
101	1716 011	Valve Stem Assy	2
102	1185 219	Retaining Ring	1
103	1720 706	Bearing	1
104	1720 361	Thrust Washer	2
105	1721 897	Handle Grip	1
106	1720 352	Hydraulic Control Handle	1
107	1720 342	Pillow Block	1
108	1185 848	Nut # 10-24	2
109	1100 115	Screw # 10-24 x 1/2	2
110	1187 559	Shake Proof Washer	2
111	1721 620	Hydraulic Valve Seal, Spring and Gasket Kit	1
112	1720 302	Hydraulic Valve	1
113	1121 507	Hex Nut 1/4-20	2
114	1100 123	Screw 1/4-20 x 1-1/4	2
115	1185 839	Shake Proof Washer	2
116	1185 811	Drive Pin 3/32 x 1/2	1
117	1717 563	Connector	4
118	1719 179	Hose-Cylinder to Control Valve 19-1/2" Lg	1
119	1721 899	Hose Control Valve to Filter	1



# TRACTOR ASSEMBLY MODEL 1257-01

## FIGURE 3 PARTS LIST CONTINUED

Ref. No.	Part No.	Description	No. Req'd
120	1720 296	Hose-Control Valve to Cylinder 13-3/4" Lg	1
121	1720 294	Hose-Hydro. Pkg to Hydraulic Control Valve	1
122	1720 928	Extension Spring	1
123	1714 788	Hydraulic Cylinder Assy (Inc 124-131)	1
124	1721 625	Cylinder Head	1
125	1721 626	"O" Ring	3
126	1721 627	Tube	1
127	1721 628	Washer	2
128	1721 629	Piston Rod	1
129	1721 630	Guide	1
130	1721 631	"O" Ring	1
131	1721 632	Clevis	1
132	1107 041	Capscrew 1/2-13 x 2-3/4	1
133	1714 783	Spacer	1
134	1107 385	Flat Washer	1
135	1708 125	Clevis Pin 1/2 x 1-1/16	1
136	1100 349	Cotter Pin 1/8 x 3/4	1
137	1722 156	Brake Caliper Assy (138-151) See page 6 for Illust.	1
138	1719 558	Carrier - Solid Side	1
139	1719 560	Puck	2
140	1719 569	Rivet	4
141	1719 561	Carrier - Cam Side	1
142	1719 562	Washer	1
143	1722 155	Spring	2
144	1719 559	Spacer	2
145	1722 066	Actuating Cam	1
146	1719 563	Actuator	1
147	1719 567	Spring	1
148	1719 564	Washer	1
149	1719 565	Snap Ring	1
150	1111 688	Capscrew 1/4-28 x 2	2
151	1100 241	Lock Washer 1/4	2
152	1722 083	Spring Bracket	1
153	1892 471	Extension Spring	1
154	1722 171	Pivot Block	1
155	1185 304	Retaining Ring	1
156	1182 563	Hex Nut 5/16-18	2
157	1177 548	Shake Proof Washer 5/16	2
158	1722 169	Brake Rod	1
159	1100 346	Cotter Pin 3/32 x 3/4	1
160	1185 597	Drive Pin 3/16 x 1-1/8	1

Ref. No.	Part No.	Description	No. Req'd
161	1722 397	Brake Arm	1
162	1722 399	Brake Pedal	1
163	1719 539	Pedal Pad	1
164	1720 529	Thrust Washer	1
165	1720 114	Spacer	1
166	1185 732	Retaining Ring	1
167	1893 445	Washer	2
168	1104 435	Woodruff Key 1/8 x 5/8	1
169	1110 108	Lock Nut 3/8-16	2
170	1721 917	Knob	1
171	1721 925	Control Handle	1
172	1722 146	Control Shaft	1
173	1706 743	Clevis Pin 5/16 x 3/4	1
174	1720 523	Neutralizer Arm	2
175	1704 692	Roll Pin 1/8 x 1	4
176	1720 962	Interlocking Switch Cam	1
177	1722 141	Stop Collar	1
178	1722 154	Torsion Spring	1
179	1722 145	Parking Brake Arm	1
180	1721 516	Adjusting Nut	1
181	1107 381	Flat Washer 1/4	1
182	1721 229	Clevis Pin	1
183	1185 850	Cotter Pin 5/64 x 3/4	1
184	1721 515	Adjusting Stud	1
185	1712 569	Compression Spring	1
186	1177 509	"O" Ring	1
187	1720 262	Parking Pawl	1
188	1720 603	Control Mount	1
189	1100 243	Lock Washer 3/8	14
190	1106 936	Capscrew 3/8-16 x 2-1/2	2
191	1106 923	Capscrew 3/8-16 x 1-1/4	1
192	1107 383	Flat Washer 3/8	3
193	1106 919	Capscrew 3/8-16 x 1	2
194	1721 909	Control Mount Support	1
195	1100 241	Lock Washer 1/4	1
196	1110 106	Lock Nut 1/4-20	1
197	1106 832	Capscrew 1/4-20 x 5/8	1
198	1722 152	Adjusting Bracket	1
199	1720 604	Locking Arm	1
200	1700 065	Bowed Washer	1
201	1185 849	Retaining Ring	1
202	1720 594	Control Arm	1
203	1185 469	Drive Pin	1
204	1118 802	Retaining Ring	1
	1721 599	Hydrostatic Fluid 1 qt	2

# TRACTOR ASSEMBLY MODEL 1257-01

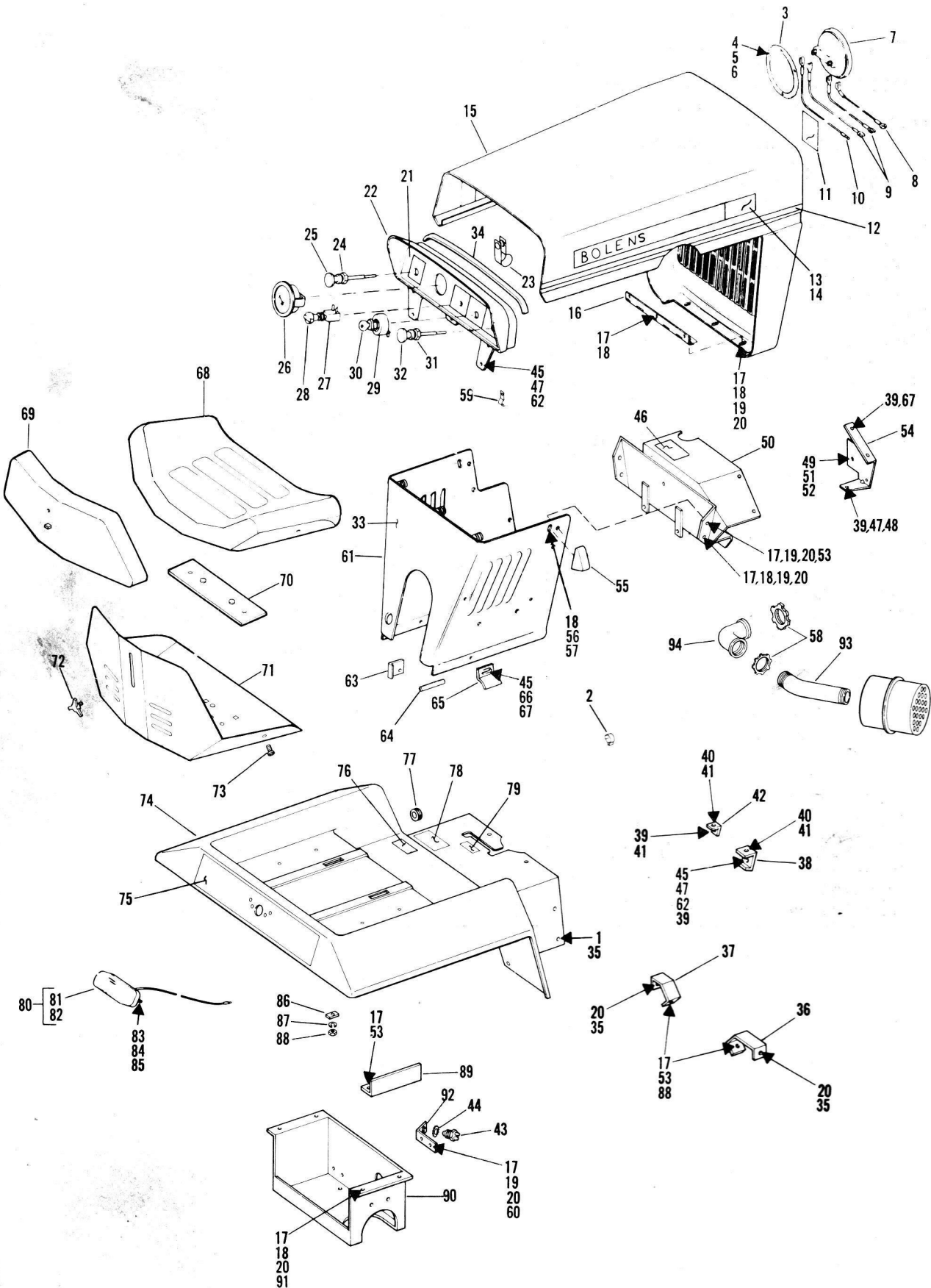

FIGURE 4

# TRACTOR ASSEMBLY MODEL 1257-01

## FIGURE 4 PARTS LIST

Ref. No.	Part No.	Description	No. Req'd	Ref. No.	Part No.	Description	No. Req'd
1	1185 498	Speed Nut 5/16-18	4	48	1100 106	Lock Nut 1/4-20	1
2	1894 291	Cable Clip	2	49	1114 755	Mach Screw #10-32 x 5/8	1
3	1719 708	Retaining Ring	2	50	1722 061	Heat Shield	1
4	1185 807	Rivet	6	51	1100 240	Lockwasher #10	1
5	1185 748	Wave Washer	6	52	1109 845	Hex Nut #10-32	1
6	1185 746	Spring Clip	6	53	1106 874	Capscrew 5/16-18 x 3/4	7
7	*	Headlight (GE4406)	2	54	1722 102	Heat Deflector	1
8	1717 394	Lead Wire - Headlight	1	55	1717 232	Latch	2
9	1717 370	Lead Wire - Headlight	2	56	1713 233	Flat Washer 5/16 Spec	4
10	1717 369	Lead Wire - Headlight	1	57	1185 261	Lockwasher 5/16 Dished	2
11	1721 386	Husky Grille Decal	1	58	1721 036	Lock Nut 1" NPT	2
12	1717 859	Tape Stripe 68" LG	1	59	1721 037	Cable Clip	1
13	1722 073	Hood Decal LH	1	60	1106 876	Capscrew 5/16-18 x 7/8	2
14	1722 072	Hood Decal RH	1	61	1721 200	Rear Panel	1
15	1717 220	Hood and Grille Assy w/o Decals	1	62	1121 507	Hex Nut 1/4-20	6
16	1717 246	Hinge	1	63	1721 913	Clip	1
17	1100 242	Lockwasher 5/16-18	22	64	1177 550	Drive Pin 5/16 x 2-1/2	1
18	1106 872	Capscrew 5/16-18 x 5/8	13	65	1714 642	Brace	2
19	1107 382	Flat Washer 5/16	13	66	1115 931	Mach Screw 1/4-20 x 5/8	2
20	1110 107	Lock Nut 5/16-18	15	67	1185 456	Tinnerman, Nut 1/4	4
21	1721 886	Instrument Panel Decal	1	68	1721 881	Seat Pad	1
22	1717 249	Instrument Panel	1	69	1721 882	Back Rest	1
23	1721 037	Cable Clamp	1	70	1721 879	Seat Doubler	1
24	1722 105	Choke (Inc 25)	1	71	1721 880	Seat Pan	1
25	1721 183	Choke Knob and Wire Only	1	72	1721 883	Knob	1
26	1714 146	Ammeter	1	73	1185 870	Sems Screw 1/4-20 x 1/2	3
27	1717 256	Light Switch (Inc 28)	1	74	1721 845	Fender	1
28	1718 231	Light Switch Knob Only	1	75	1721 889	Decal (Reflector)	1
29	1722 275	Ignition Switch (Inc 30)	1	76	1721 190	Hydro, Oil Instrument Decal	1
30	1718 266	Key Only	1	77	1185 585	Flip Grommet	1
31	1722 106	Throttle Control (Inc 32)	1	78	1721 888	Park-Lock Decal	1
32	1721 182	Throttle Knob and Wire Only	1	79	1721 072	PTO Drive Decal	1
33	1721 887	Instruction Decal	1	80	1805 342	Taillight Assy (Inc 81 and 82)	1
34	1717 599	Pad	1	81	*	Bulb (GE 1895)	1
35	1185 872	Screw 5/16-18 x 5/8	6	82	1805 110	Lens Only	1
36	1721 904	Fender Support RH	1	83	1116 197	Mach Screw #6-32 x 1/2	2
37	1721 903	Fender Support LH	1	84	1109 764	Hex Nut #6-32	2
38	1721 907	Fender Support	1	85	1103 989	Lockwasher #6	2
39	1106 830	Capscrew 1/4-20 x 1/2	2	86	1721 876	Reinforcing Plate	2
40	1185 894	Phillips Hd Scr 1/4-20 x 1/2	2	87	1100 243	Lockwasher 3/8	2
41	1185 893	Tinnerman Nut 1/4-20	3	88	1110 108	Lock Nut 3/8-16	4
42	1721 908	Fender Support	1	89	1722 107	Divider	1
43	1720 963	Interlock Switch	1	90	1721 892	Fender Support	1
44	1185 844	Shakeproof Washer 9/16	1	91	1704 930	Clamp	1
45	1107 381	Flat Washer 1/4	8	92	1722 142	Interlock Bracket	1
46	1721 249	Warning Decal	1	93	1722 103	Exhaust Pipe	1
47	1100 241	Lockwasher	7	94	1721 270	Elbow 90°	1

\* Not stocked. Purchase from your local automotive or electrical supplier.

# TRACTOR ASSEMBLY MODEL 1257-01

## DUAL LIGHT GROUP - WIRING DIAGRAM

**NOTE:**

WIRES DESIGNATED BY COLOR WITH AN ASTERISK (\*) ARE CONTAINED IN WIRING HARNESS PART NUMBER 1722131, WIRES DESIGNATED BY COLOR ONLY ARE CONTAINED IN WIRING HARNESS PART NUMBER 1722062

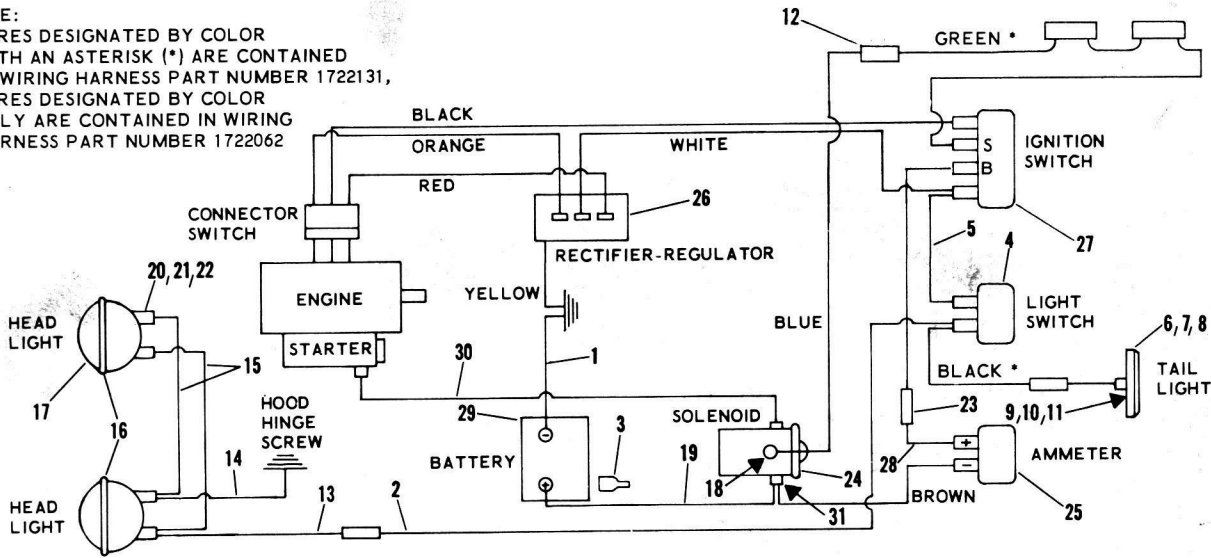

FIGURE 5

FIGURE 5 PARTS LIST

Ref. No.	Part No.	Description	No. Req'd
1	1716 636	Lead Assembly (Ground)	1
2	1721 018	Lead Wire Switch to Headlight Wire	1
3	1721 413	Term. Boot	1
4	1717 256	Light Switch	1
5	1722 063	Lead (Light Sw to IGN Sw)	1
6	1805 342	Taillight Assy (Inc 7 & 8)	1
7	*	Bulb (GE1895)	1
8	1805 110	Lens Only	1
9	1103 989	Lockwasher #6	2
10	1109 764	Nut #6-32	2
11	1116 197	Screw #6-32 x 1/2	2
12	1721 038	Connector	1
13	1717 369	Lead Headlight	1
14	1717 394	Lead Headlight	1
15	1717 370	Lead Headlight	2
16	1719 708	Retaining Ring	2

Ref. No.	Part No.	Description	No. Req'd
17	*	Headlight Bulb (GE4406)	2
18	1109 845	Hex Nut #10-32	1
19	1722 108	Battery Lead	1
20	1185 746	Spring Clip	6
21	1185 807	Rivet, Semi Tubular 3/16 x 7/8	6
22	1185 748	Wave Washer	6
23	1720 976	Fuse 20 AMP	1
24	1717 048	Solenoid	1
25	1714 146	Ammeter	1
26	**	Rectifier Regulator	1
27	1722 275	Ignition Switch	1
28	1722 088	Lead Wire, Ammeter to IGN Switch	1
29	1718 027	BATT. 12V-45 AMP	1
30	1722 109	Lead Wire, Sol. to Starter	1
31	1182 563	Hex Nut 5/16-18	2

\*Not stocked. Purchase from your local automotive or electrical supplier.

\*\*Not stocked. Purchase from your local Tecumseh Products Co, Lauson-Power Products Parts Outlet.