

TILLER ATTACHMENT MODEL 18090-01

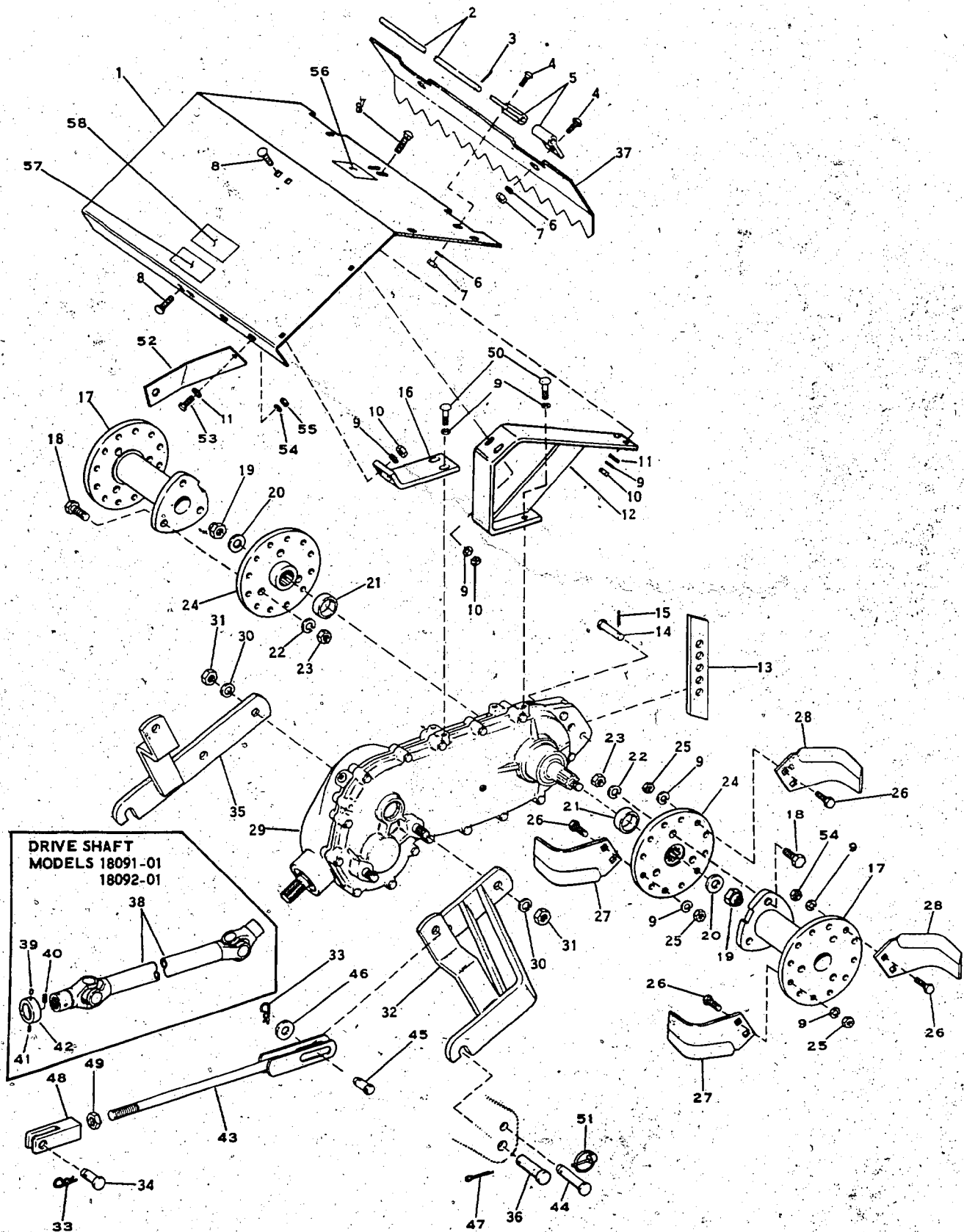

TILLER ATTACHMENT MODEL 18090-01

Ref. No.	Part No.	Description	No. Req'd
1	1723 033	Hood	1
2	1723 031	Hinge Pin	1
3	1100 346	Cotter Pin 3/32 x 3/4	2
4	1111 265	Carriage Bolt 5/16-18 x 3/4	4
5	1718 196	Hinge	4
6	1100 242	Lockwasher 5/16	4
7	1182 563	Hex Nut 5/16-18	4
8	1111 285	Carriage Bolt 3/8-16 x 1	6
9	1100 243	Lockwasher	54
10	1110 108	Lock Nut 3/8-16	6
11	1107 383	Flat Washer 3/8	3
12	1719 680	Rear Hood Bracket	1
13	1718 189	Shoe Center	1
14	1708 336	Clevis Pin	1
15	1100 350	Cotter Pin 1/8 x 1	1
16	1718 205	Front Hood Bracket	1
17	1718 138	Spacer	2
18	1107 033	Hex Head Capscrew 1/2-13 x 1-3/4	6
19	1185 229	Hex Lock Nut 5/8-18	2
20	1800 041	Spacer Washer	2
21	1718 170	Sleeve	2
22	1100 245	Lockwasher 1/2	6
23	1121 511	Hex Nut 1/2-13	6
24	1718 140	Tiller Hub	2
25	1110 150	Hex Nut 3/8-24	48
26	1100 010	Hex Head Capscrew 3/8-24 x 1-1/4	48
27	1709 387	R. H. Bend Tine	12
28	1709 388	L. H. Bend Tine	12
29	1723 036	Gear Case Assembly	1
30	1100 247	Lockwasher	4

Ref. No.	Part No.	Description	No. Req'd
31	1121 513	Hex Nut 5/8-11	4
32	1718 304	Lift Arm Assembly - L. H.	1
33	1703 011	Spring Cotter	4
34	1713 553	Clevis Pin 5/8 x 1-5/8	2
35	1718 301	Lift Arm Assembly - R. H.	1
36	1718 773	Clevis Pin	2
37	1723 032	Leveling Board	1
38	*	Drive Shaft Assembly (Includes Ref #39, 40, 41, and 42)	1
39	1185 917	Drive Pin 7/32 x 1/2	1
40	1722 916	Compression Spring	1
41	1185 916	Groove Pin 3/16 x 3/8	1
42	1722 914	Locking Collar	1
43	1718 307	Lift Rod	2
44	1721 609	Clevis Pin	2
45	1713 501	Clevis Pin	2
46	1107 386	Flat Washer 5/8	2
47	1100 351	Cotter Pin 1/8 x 1-1/4	2
48	1714 573	Rod End	2
49	1108 891	Jam Nut 5/8-11	2
50	1719 673	Capscrew 3/8-16 x 1-1/4	4
51	1719 672	Klick Pin	2
52	1723 029	Support Bracket	1
53	1106 918	Hex Head Screw 3/8-16 x 1	1
54	1185 667	Star Washer 3/8	1
55	1121 551	Hex Nut 3/8-16	1
56	1715 633	Decal - Bolens	1
57	1715 670	Decal - Caution	1
58	1719 335	Decal - Tiller Instr.	1

* Drive Shaft 1722630 (NLA) for Tractor Model 1477.

Drive Shaft use 1723964 for Tractor Model 1886.

TILLER ATTACHMENT MODEL 18090-01

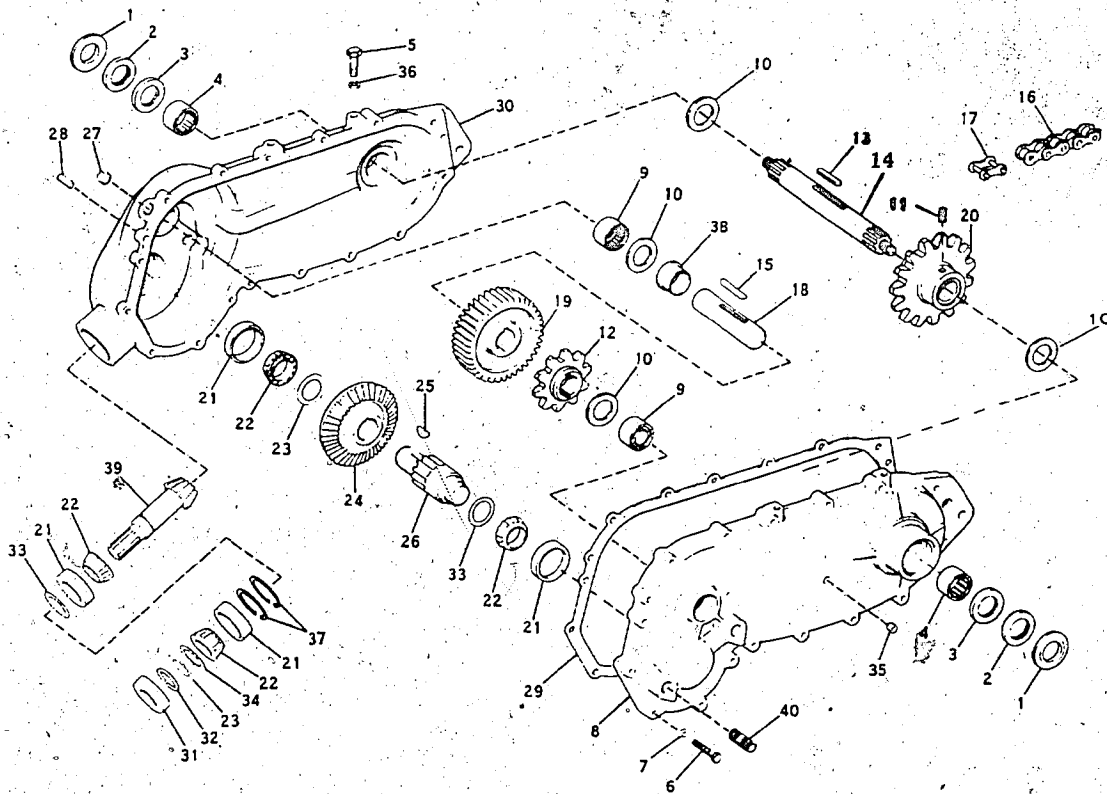

Ref. No.	Part No.	Description	No. Req'd.
1	1718 153	Seal Washer	2
2	1185 630	Oil Seal	2
3	1185 629	Oil Seal	2
4	1185 721	Needle Bearing	2
5	1719 673	Capscrew 3/8-16 x 1-1/4	4
6	1100 799	Hex Head Capscrew 5/16-18 x 1-3/4	16
7	1100 242	Lockwasher 5/16	16
8	1720 397	Gearcase Cover (Inc Ref #21)	1
9	1185 720	Needle Bearing	2
10	1710 530	Thrust Washer	4
11	1103 494	Set Screw 3/8-16 x 1/2	1
12	1718 147	Sprocket 10-Tooth 1 Inch Pitch	1
13	1718 149	Square Key 5/16 x 2-1/4	1
14	1721 592	Tine Shaft	1
15	1718 686	Special Key 5/16 x 1/4	2
16	1718 151	Roller Chain 1 Inch Pitch	1
17	1718 152	Roller Chain Connector	1
18	1718 394	Shaft	1
19	1718 393	Gear 39 Tooth	1
20	1721 591	Sprocket 15-Tooth 1 Inch Pitch	1

Ref. No.	Part No.	Description	No. Req'd.
21	1177 343	Bearing Cup	4
22	1177 262	Bearing Cone	4
23	1718 781	Shim 1.265 x .005	As Req'd.
24	1718 391	Bevel Gear 40 Tooth	1
25	1708 382	Woodruff Key	1
26	1718 392	Pinion & Shaft	1
27	1706 566	Plug Assembly	1
28	1185 206	Drive Pin	2
29	1718 389	Gasket	1
30	1720 396	Tiller Case (Includes Ref #21)	1
31	1185 734	Oil Seal	1
32	1185 732	Retaining Ring	1
33	1719 443	Shim 2.320 x .005	As Req'd.
34	1719 271	Shim 1-1/4 x .020	As Req'd.
35	1185 741	Pipe Plug 1/8	1
36	1100 243	Lockwasher 3/8	4
37	1185 733	Retaining Ring	2
38	1718 484	Spacer	1
39	1718 390	Pinion 13 Tooth	1
40	1113 755	Stud 5/8-11 x 2-1/4	4