

SECTION 12: Illustrated Parts

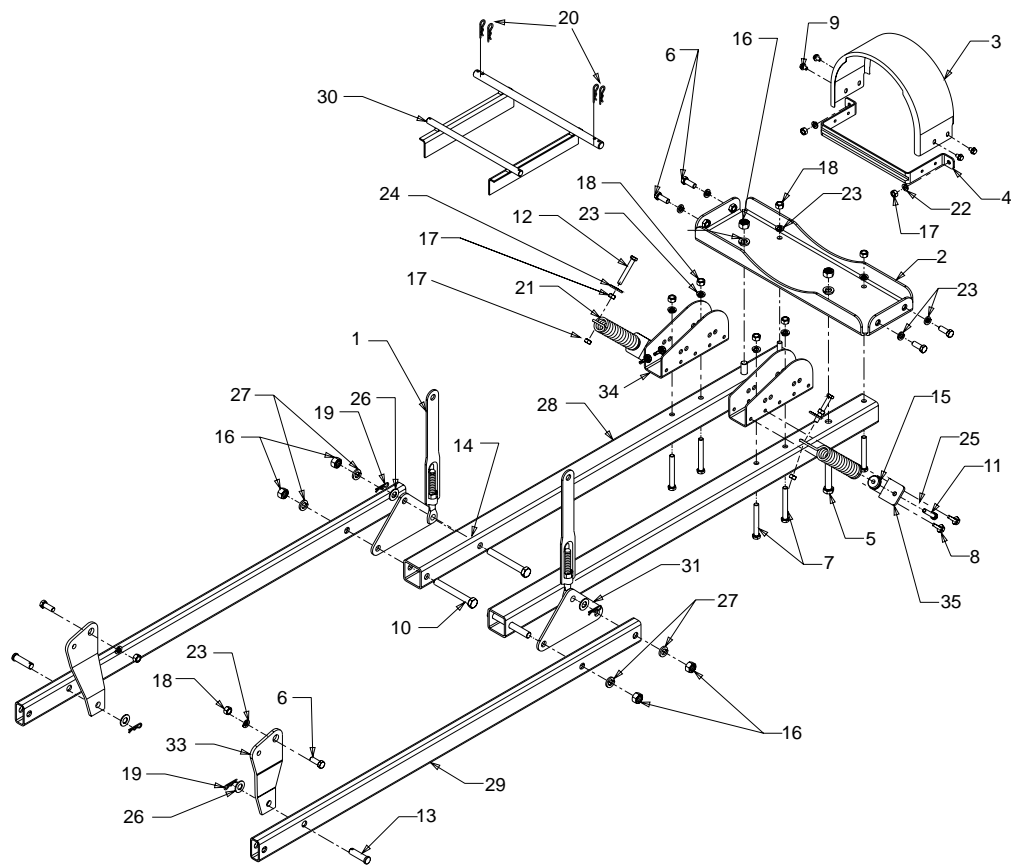

REF. NO.	PART NO.	QTY.	DESCRIPTION	REF. NO.	PART NO.	QTY.	DESCRIPTION
1	17304	2	Lift Asm:Deck Link:Front	19	714-0101	4	Pin:Cot:Int .08 x 1.42
2	684-0110	1	Brkt Asm:Hsg.	20	714-0147	4	Pin:Cot:.125 x 1.75 Internal
3	703-2869	1	Cvr:Belt	21	732-0813	2	Spr:Extn:1.25 O.D. x 7.25
4	703-2870	1	Brkt:Cvr:Belt	22	736-0119	2	Wash:Lock:5/16:Regular Duty
5	710-0182	2	HHCS:1/2-13:3.00:GR5:Std.	23	736-0169	12	Wash:Lock:3/8:Regular Duty
6	710-0514	6	HHCS:3/8-16:1.00:GR5:Std.	24	736-0231	2	Wash:Fl: .344 I.D. x 1.125 O.D.
7	710-0521	6	HHCS:3/8-16:3.00:GR8:Std.	25	736-0242	2	Wash:Belvl:.340 I.D. X .872 O.D.
8	710-0607	4	Scr. TT 5/16-18:.50 HxIndWsh.	26	736-0272	4	Wash:Fl:.510 X 1.00 X .060
9	710-0653	4	Scr.TT:1/4-20:.375:HxIndWsh.	27	736-0921	6	Wash:Lock:1/2:Regular Duty
10	710-0786	4	HHCS:1/2-13:4.00:Gr5:Std.	28	750-1057	2	Tube:Lift:2.0 x 2.0 x 42.0 Lg.
11	710-0959	2	HHCS:5/16-18:1.50:Gr5:Spec.	29	750-1059	2	Tube:Lift:1.0 x 2.0 x 43.0 Lg.
12	710-3073	2	HHCS:5/16-18: 2.50:Gr5:Std.	30	784-5148A	1	Guide Bracket Assy.
13	711-0231	2	Pin:Clv:.50 Dia. x 1.59 Lg.	31	784-5199	2	Brkt:Lift Plate
14	711-0332	2	Pin:Clv:.50 Dia. x .78 Lg.	32	784-5203	1	Brkt:Hngr:RR LH
15	711-0509	2	Ins:Spring	33	784-5204	1	Brkt:Hngr:RR RH
16	712-0206	6	Nut:1/2-13:GrA:Hx	34	784-5211B	2	Brkt:Idlr:Supt.
17	712-3010	4	Nut:5/16-18:GrB:Hx	35	784-5686	2	Brkt:Spr:Mt.
18	712-3017	8	Nut:3/8-16:GrB:Hx				

DRIVE ASSEMBLY

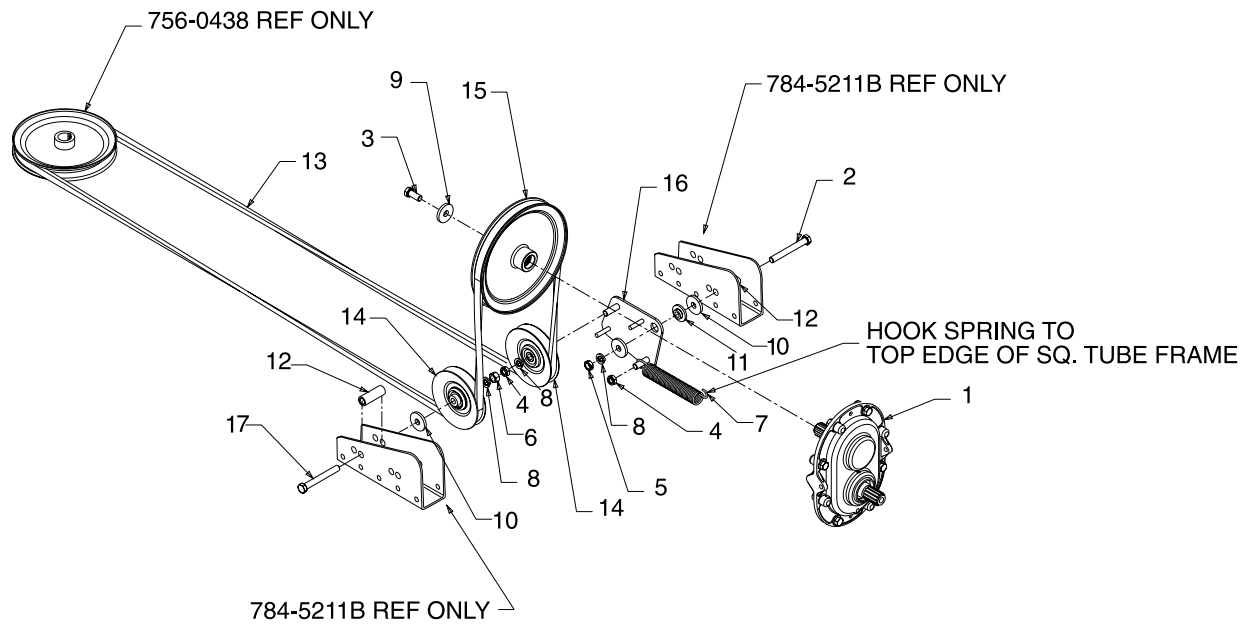

REF. NO	PART NO.	QTY.	DESCRIPTION
1	684-0113	1	Box Asm:Spkt.
2	710-0521	1	HHCS:3/8-16:3.00:Gr8:Std.
3	710-0696	1	HHCS:3/8-24:.875:Gr8:Std.
4	712-0116	2	Nut:Jam:3/8-24:Ins Lock
5	712-0266	1	Hex Cent L-Jam Nut 3/8-16
6	712-3017	1	Hx. Nut:3/8-16:GrB:
7	732-0491	1	Spring:Extn:.87 Dia. x 6.00 Lg.
8	736-0169	3	Wash:Lock:3/8:Regular Dh
9	736-0235	1	Flat Wash. .406 I.D. x 1.25 O.D.
10	736-0247	2	Flat Wash. .406 I.D. x 1 1/4 O.D.
11	738-0347	1	Shld Spacer .625 I.D. x .169
12	750-0668	2	Spacer .32 I.D. x .625 O.D. x 1.74
13	754-0458	1	Belt:V Typ:A Sect. x 126.0 Poly
14	756-0487	2	V-Belt Idler-.38 I.D. x 4.0 Dia.
15	756-0496	1	Pulley :Dr.:7.00 Dia.
16	784-5200	1	Brkt Asm:Idlr.
17	710-3279	1	HHCS:3/8-16:4.25:Gr.5

CARRIAGE ASSEMBLY

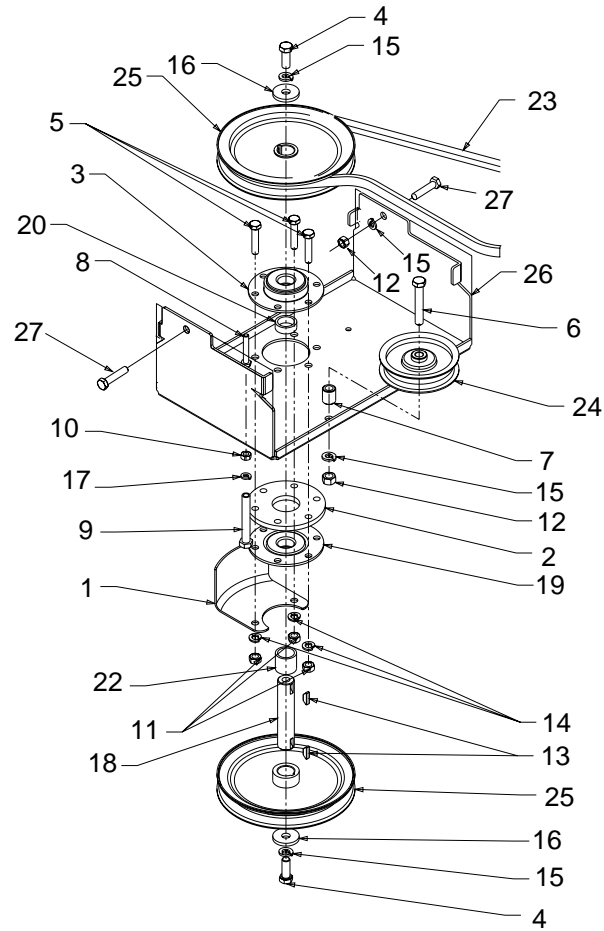

REF. NO.	PART NO.	QTY.	DESCRIPTION	REF. NO.	PART NO.	QTY.	DESCRIPTION
1	05406	1	Belt Guard	14	736-0119	3	Wash:Lock: 5/16:Regular Duty
2	14088B	1	Plt:Spdl:Spcr.	15	736-0169	5	Wash:Lock:3/8:Regular Duty
3	15297A	1	Open Brg. Housing 1.85	16	736-0247	2	Flat Washer .406 I.D. x 1 1/4 O.D.
4	710-0591	2	HHCS:3/8-24:1.00:Gr.5:Lock	17	736-0329	1	Wash:Lock:1/4:Regular Duty
5	710-0624	3	HHCS:5/16-24:1.50:Gr.5:Std.	18	738-0680	1	Shaft- .787 Dia. x 3.81 Lg.
6	710-3011	1	HHCS:3/8-16:2.25:Gr.5:Std.	19	741-0163A	1	Hsg. Asm.:Bearing
7	711-0396	1	Spcr.:.385 x .623 x .750 Lg.	20	750-0456	1	Spacer .790 I.D. x .347 Lg.
8	711-0747	1	Pin:Gde: .250 Dia. x 1.68 Lg.	22	750-0660	1	Spacer .80 I.D. x 1.00 O.D. x .900
9	711-0793	1	Pin:Clevis:.375 Dia. x 2.63 Lg.	23	754-0229	1	Belt: V: 1/2 x 52.00 Lg.
10	712-0107	1	Nut:Lock:1/4-20	24	756-0405	1	Fl-Idler w/ Flanges 3.75 O.D.
11	712-0123	3	Hx. Nut:5/16-24:Gr.A:	25	756-0438	2	Pulley:V Typ:6.50 O.D.
12	712-0798	3	Hx. Nut:3/8-16:Gr. A	26	784-5146	1	Brkt: Carriage
13	714-0161	2	Key:Hi-Pro 3/16 X 5/8	27	710-0514	2	HHCS. 3/8-16:1.00 Gr.5

UPPER CHUTE AND CHUTE CONTROLS

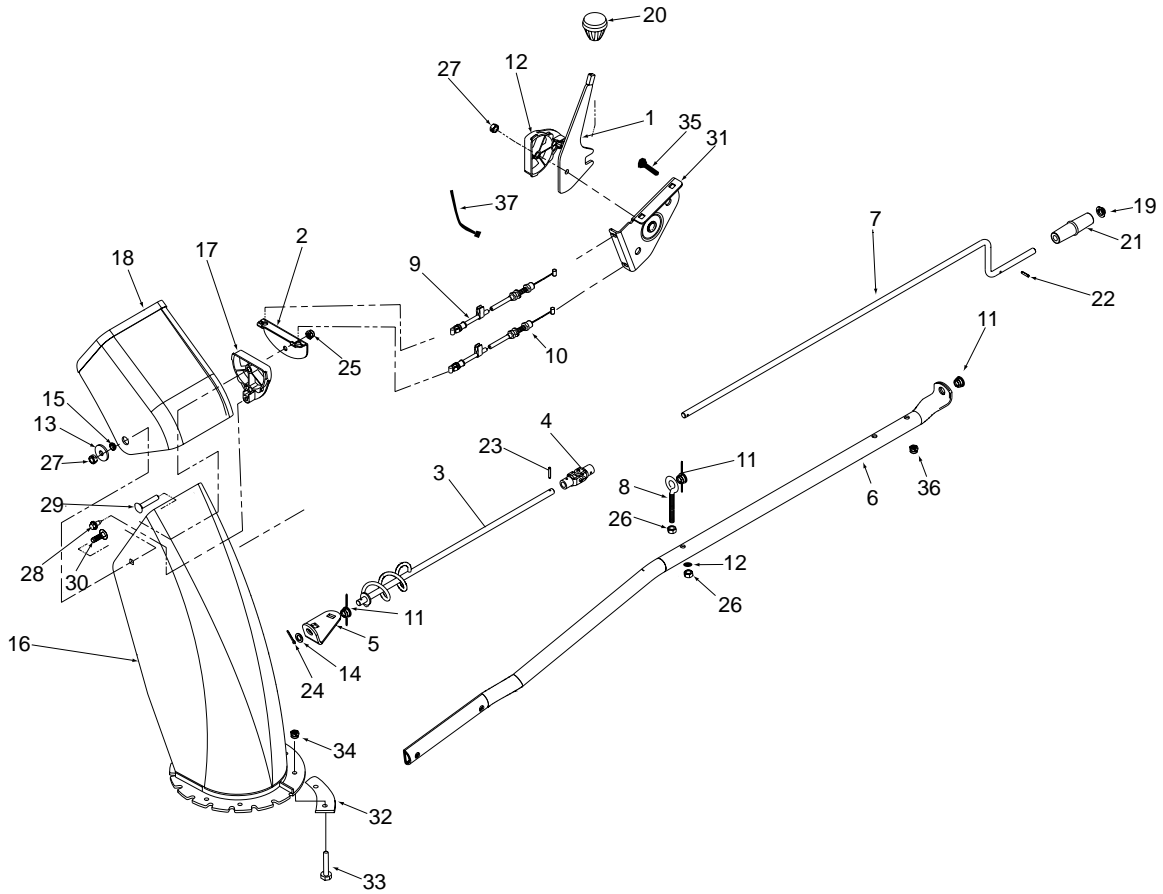

REF. NO.	PART NO.	QTY.	DESCRIPTION	REF. NO.	PART NO.	QTY.	DESCRIPTION
1	784-5604	1	Hndl:Tilt:Chute	20	720-0232	1	Knob:Shift:1.60 O.D. x 1.56
2	784-5594	1	Cable Bracket	21	720-0201A	1	Knob:Crk:1.00 Dia. x 3.2 Chute
3	784-5401	1	CHute Crank Assy.18.0 Lg. - RH	22	715-0138	1	Pin:Roll:1/8 O.D. .:63
4	784-5149	1	Block Ass'y:Joint	23	715-0129	1	Spiral Pin - 1/8 Dia. x .812 Lg.
5	784-5123	1	Chute Crank Bracket	24	714-0507	1	Pin:Cot: 3/32 x .750
6	749-3072	1	Tube:Supt:Crank	25	712-0429	1	Nut:Hx.: 5/16-18:Gr.C:Lock
7	747-0931	1	Rod:Crk:Chute .380 Dia. x 28.0 Lg.	26	712-0267	2	Hx. Nut:5/16-18:Gr.A:
8	747-0481A	1	Eye Bolt 5/16-18 x 3.0 Lg.	27	712-0158	2	Nut:Lock:5/16-18:Cen.
9	746-0903	1	Cable:Chute:w/Culp, 66 Lg.	28	710-0896	1	Scr:1/4-14:.625:HxIndWsh
10	746-0902	1	Cable:Chute 66 Lg.	29	710-0458	1	Carriage Bolt 5/16-18 X 1.75
11	741-0475	3	Plastic Bushing .380 I.D.	30	710-0276	1	Scr:Carr:5/16-18:1.00
12	736-0242	2	Wash:Belvl.:.340 I.D. x .872 O.D.	31	603-0302	1	Asm:Chute Tilt Brkt
13	736-0231	1	Wash:Fl.:.344 I.D.:1.125 O.D.:.12	32	731-0851A	3	Chute Flange Keeper
14	736-0140	1	Fl. Wash .385 I.D. x .62 O.D. x .06	33	710-3015	6	Hx. Bolt 1/4-20:.75 Lg.
15	731-1319	1	Spcr:Chut:Pivot	34	712-3027	6	Hx. Flg. Nut 1/4-20
16	731-1318	1	Chut.:Extended 6" Dia.	35	710-0262	2	Carr. Bolt 5/16-18:1.50 Gr.2
17	731-1313B	2	Gde:Cable:Chute Tilt	36	712-3004A	2	Nut-Lock 5/16-18 Gr.5
18	731-0849	1	6" Dia. Upper Chute	37	725-0157	1	Cable Tie
19	726-0100	1	Cap:Push x 3/8 Rod				

BLOWER ASSEMBLY

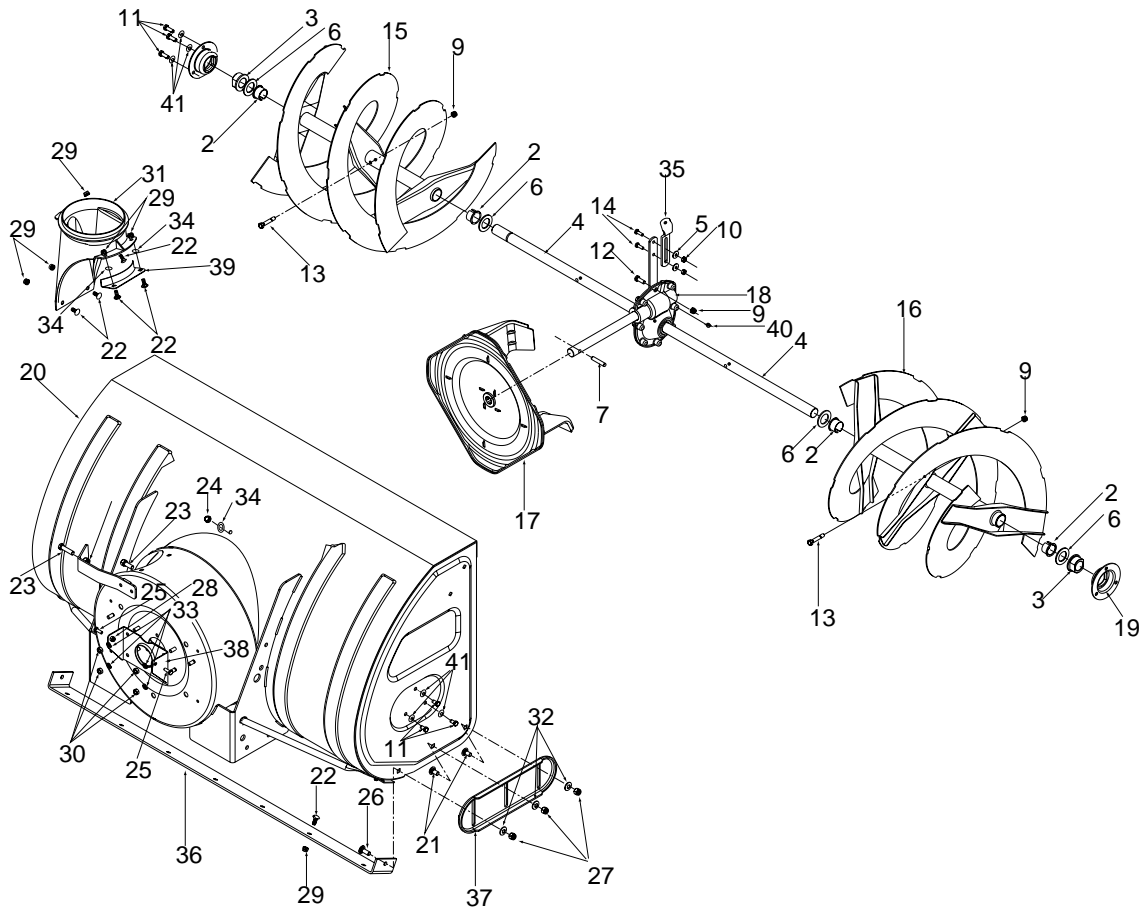

REF. NO.	PART NO.	QTY.	DESCRIPTION	REF. NO.	PART NO.	QTY.	DESCRIPTION
1	784-5710	1	Plt:Supt.	22	710-0451	12	Bolt:Car:5/16-18:.75
2	741-0494	4	Bush:Flg:1.05 I.D. x 1.16 O.D.	23	710-0520	2	HHCS:3/8-16:1.50:Gr.5:Std.
3	741-0192	2	Brg:Flg:w/Flats	24	710-0726	1	Scr:AB:5/16-12:0:.750: HxIndWsh
4	738-0492	1	Spiral Axle 1.00 X 44.12	25	710-3015	2	HHCS:1/4-20:.75:Gr.5:Std.
5	736-0270	2	Wash:Bell:.265 x .75 x .062	26	710-3168	2	Bolt:Carr:3/8-16
6	736-0250	4	Fl. . 1.00 I.D. x 1.75 O.D. X .1	27	712-0130	8	Nut:Hx.:3/8-16:Gr.C:Lock
7	715-0118	1	Spring Pin Spir 5/16 Dia. X 1.7	28	712-0324	2	Nut:Hx: 1/4-20:Gr.C:Lock
9	712-0429	3	Hx. Nut:: 5/16-18:Gr.C:Lock	29	712-0429	12	Nut:Hx: 5/16-18:Gr.C:Lock
10	712-0138	2	Hx. Nut:1/4-28:Gr.A	30	712-3010	4	Hx. Nut: 5/16-18:Gr.B
11	710-0604	6	Scr.TT HxIndWash 5/16-18:.625 Lg	31	731-1696	1	Chute: Adap:6" Dia.
12	710-3038	1	HHCS:5/16-18:.875:Gr.5:Std.	32	736-0105	6	Wash:Spr:.401 x .870 x .063
13	710-0891	2	Shear Bolt 5/16 - 18 x 1-3/4	33	736-0119	4	Wash:Lock: 5/16:Regular Duty
14	710-0412	2	HHCS:1/4-28:.75:Gr.5:Std.	34	736-0242	1	Wash: Belvl:.340 I.D. x .872 O.D.
15	684-0073	1	Sprl. Asm:LH:16"	35	784-5076	1	Gear Housg.Supp.Brkt
16	684-0072	1	Sprl. Asm:RH	36	784-5696	1	Plt: Shave
17	684-0069	1	Impeller Ass'y:16"	37	784-5697	2	Shoe:Skid
18	618-0244	1	Gear Asm:Auger	38	784-5703	1	Brkt:Mt:Brg.
19	05845B	2	Hsg:Brg:1.50 DBL-T	39	784-5711	1	Brkt:Chut:6.0
20	684-0068	1	Hsg Asm:SprL:45"	40	714-0135	1	Woodruff Key 1/4 x 3/4 Dia.
21	710-0389	4	Carriage Bolt 3/8-16 x .75	41	736-0242	6	Wash. Bell .340 I.D. x .872 O.D.

AUGER GEAR ASSEMBLY

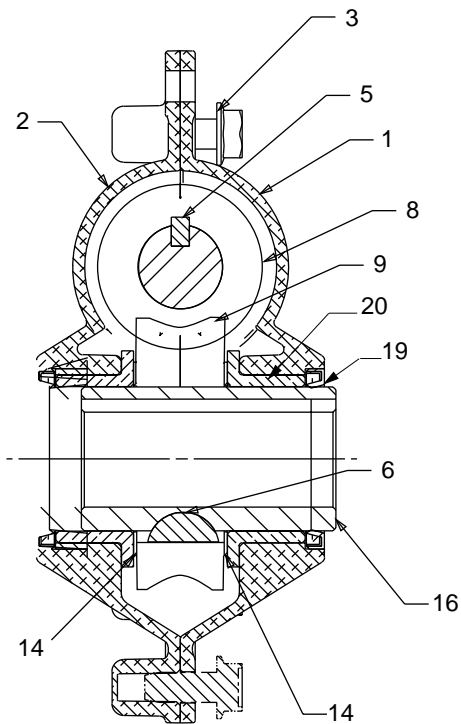
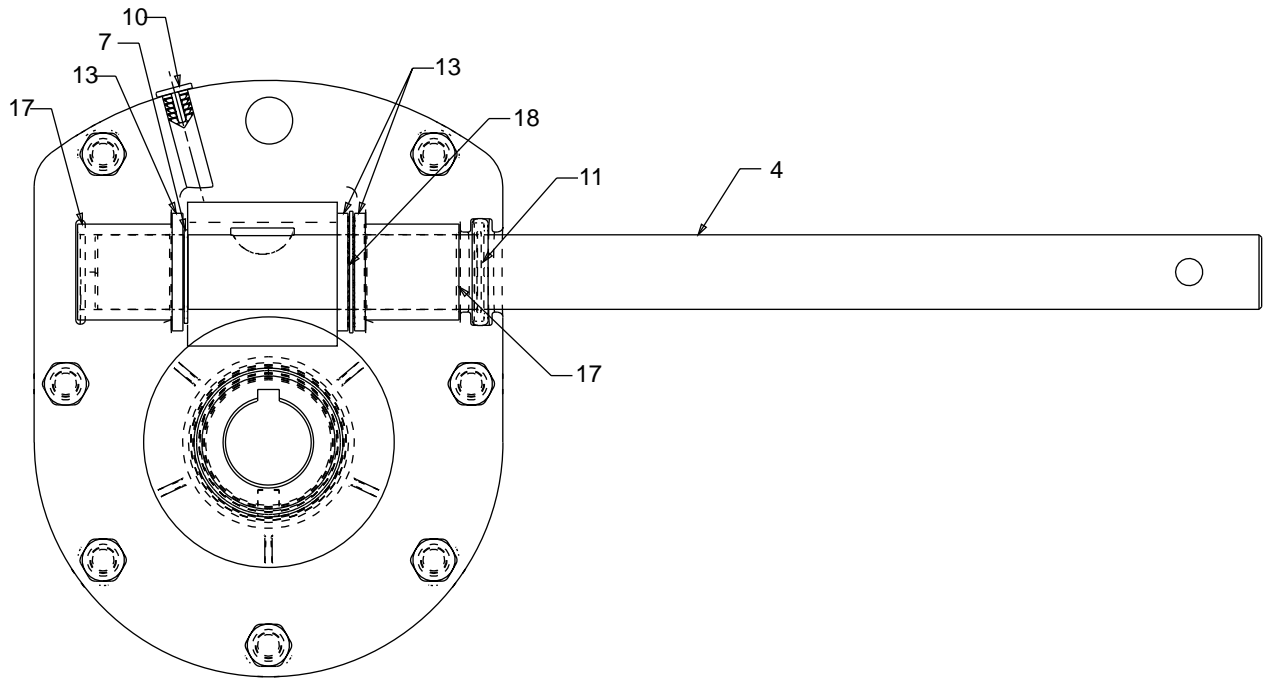

REF. NO.	PART NO.	QTY.	DESCRIPTION
1	618-0247	1	Auger Housing Ass'y, L.H.
2	618-0246	1	Auger Housing Ass'y, R.H.
3	710-1260	7	Scr. TT HxWash. 5/16-18:.75" Lg.
4	711-1097	1	Auger Input Shaft
5	714-0126	1	Key, Hi Pro 3/16 x 3/4 Dia.
6	714-0135	1	Key, Woodruff #91:1/4 x 3/4
7	716-0111	1	Retaining Ring
8	717-0299	1	Worm Gear Double Thread LH
9	717-1425	1	Worm Gear LH
10	721-0325	1	Plug
11	721-0145	1	Oil Seal
12	721-0328	.02	Sealant: Ultra Grey Loctite 5699 (Not Illustrated)
13	736-0291	3	Wash. Flat .88 I.D. x 1.380 O.D. x .125
14	736-0266	2	Wash. Fl. 1.52 I.D. x 2.0 O.D. x .30
15	737-0300	.16	Grease, Benalene 920 (Not Illust.)
16	738-0275	1	Worm Gear Shaft
17	741-0217	2	Sleeve
18	741-0184	1	Thrust Bearing
19	721-0146	2	Oil Seal
20	741-0670	2	Flange Bearing
	618-0244	1	Auger Gear Ass'y. - Complete