

Front Bumper

For FastAttach™ Compatible 600 and 800 Series Tractors
For Box Frame Compatible 600 and 800 Series Tractors

Model OEM-190-672

SECTION 1: CALLING CUSTOMER SUPPORT

If you have difficulty assembling this product or have any questions regarding the controls, operation or maintenance of this unit, please call the Customer Support Department.







Call 1- (330) 220-4MTD (4683) or 1- (800)-800-7310 to reach a Customer Support representative. Please have your unit's model number and serial number ready when you call. See previous section to locate this information. You will be asked to enter the serial number in order to process your call.

SECTION 2: CONTENTS OF CARTON

Before beginning installation, remove all parts from the carton to make sure everything is present. Carton contents are listed below. Part numbers are shown in parentheses.

- Front Bumper - (768-0010A)

- Two Clevis Pins - (44056)  
- Two Cotter Pins - (43055)  
- Four Hex Bolts - (44283)
- Four Hex Nuts - (43083)
- Four Lock Washers - (43086)

SECTION 3: ASSEMBLY



WARNING: Before beginning installation, place the tractor on a firm and level surface. Place the PTO in the disengaged (OFF) position, stop the tractor engine and set the parking brake.

NOTE: References to LEFT and RIGHT indicate the left and right sides of the tractor when facing forward in the operator's position. Reference to the FRONT indicates the grille end; to the REAR the drawbar end.

Mounting Front Bumper to Fast Attached™ Tractor



WARNING: Muffler may be hot! Make sure engine has cooled down before installing bumper.

- To mount the bumper to the tractor, hook the notched ends (slots) of the bumper onto the shoulder bolts on the sides of the tractor frame. See Figure 1.

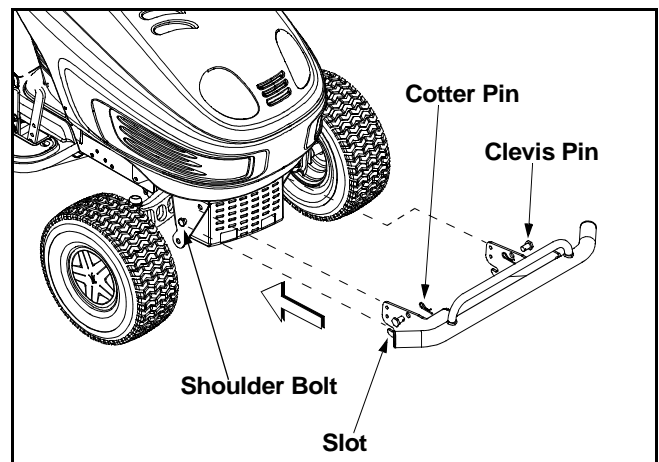

Figure 1

- Align the holes in the bumper with the holes in the tractor frame and insert the clevis pins through the holes from the outside. Secure the pins in place with the cotter pins.

Mounting Front Bumper to 600 Series Box Frame Tractor



WARNING: Muffler may be hot! Make sure engine has cooled down before installing bumper.

NOTE: The front bracket is exploded from the tractor for clarity in Figure 2.

- To mount the bumper to the tractor, slide the bumper over the front brackets, aligning the two holes in the bumper over the two upper holes in the bracket. See Figure 2.
- Insert the hex bolts from the outside through the holes and secure with the lock washers and hex nuts.

IMPORTANT: If the tractor is equipped with a muffler guard between the tractor brackets, the hex bolts should be bolted into the guard. The lock washers and nuts will not be necessary.

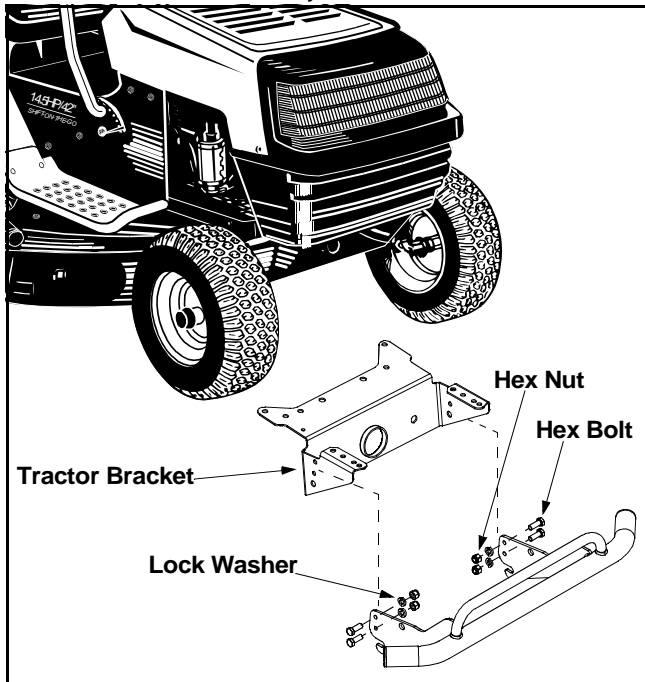

Figure 2

Mounting Front Bumper to 800 Series Box Frame Tractor



WARNING: Muffler may be hot! Make sure engine has cooled down before installing bumper.

NOTE: The front bracket is exploded from the tractor for clarity in Figure 3.

- To mount the bumper to the tractor, slide the bumper over the front brackets, aligning the two holes in the bumper over the two upper holes in the bracket. See Figure 2.
- Insert the hex bolts from the outside through the holes and secure with the lock washers and hex nuts.

IMPORTANT: If the tractor is equipped with a muffler guard between the tractor brackets, the hex bolts should be bolted into the guard. The lock washers and nuts will not be necessary.

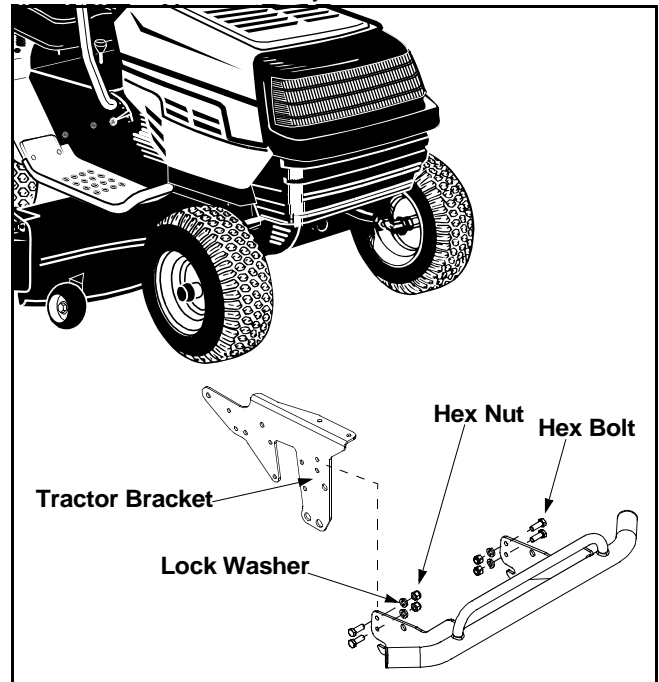

Figure 3