

ILLUSTRATED PARTS LIST

42 INCH
SNOWBLADE
ATTACHMENT
MODEL 18003-01

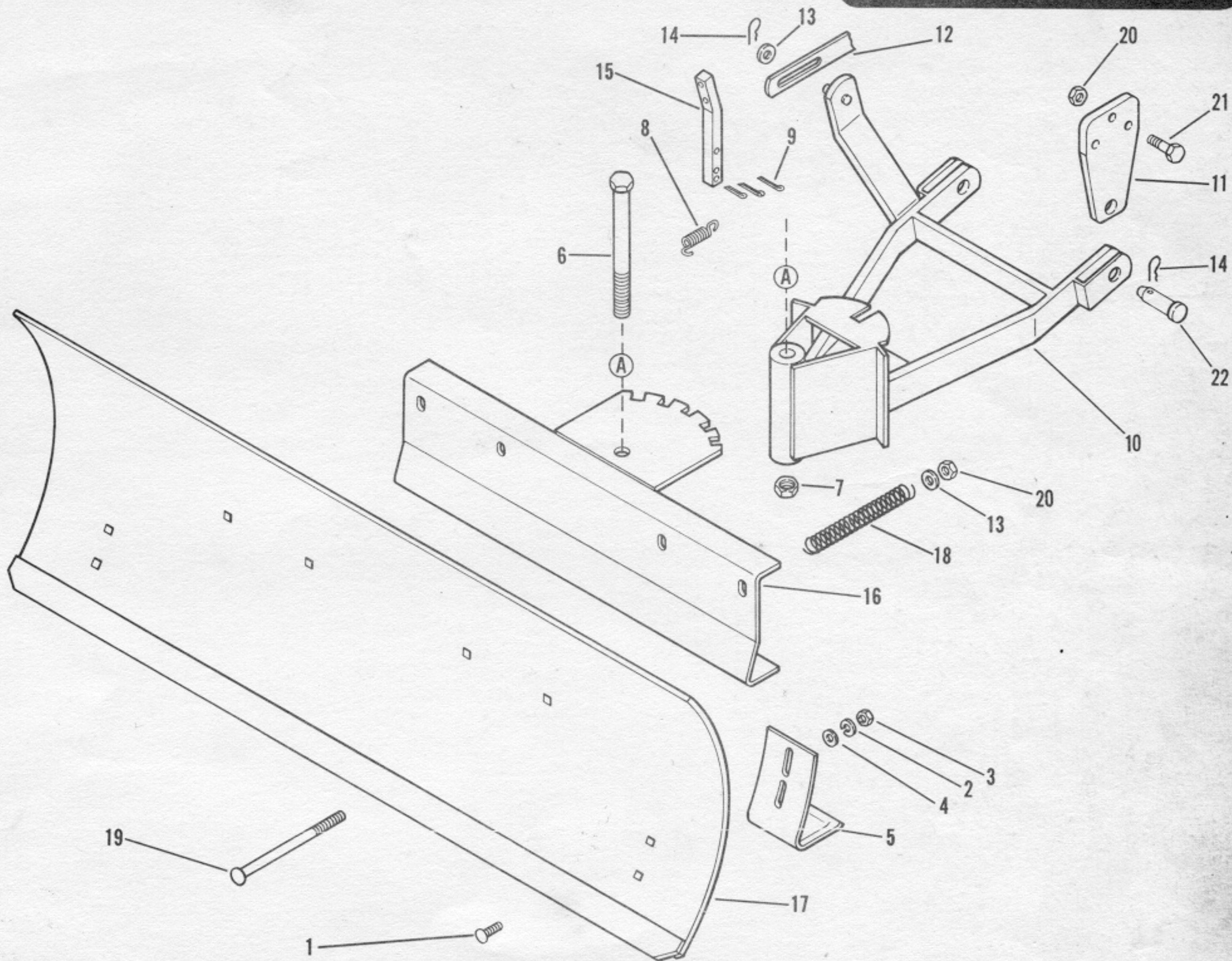

Ref. No.	Part No.	Description	No. Req'd
1	1111 266	Carriage Bolt 5/16-18 x 1	4
2	1100 242	Lock Washer 5/16	4
3	1103 839	Hex Nut 5/16-18	4
4	1107 382	Flat Washer 5/16	4
5	308 812	Shoe	2
6	1185 760	Capscrew 5/8-11 x 7	1
7	1110 112	Lock Nut 5/8-11	1
8	1701 495	Extension Spring	1
9	1100 349	Cotter Pin 1/8 x 3/4	3
10	1719 848	Hitch Arm	1
11	1720 130	Hitch Plate	2
12	1719 788	Lift Link	1

Ref. No.	Part No.	Description	No. Req'd
13	1107 383	Flat Washer 3/8	6
14	1703 011	Spring Cotter	4
15	1719 912	Latch Pin	1
16	1719 840	Spring Mount	1
17	1719 844	Blade	1
18	1707 413	Compression Spring	4
19	1111 295	Carriage Bolt 3/8-16 x 6-1/2	4
20	1110 108	Lock Nut 3/8-16	10
21	1100 046	Capscrew 3/8-16 x 1	6
22	1713 501	Clevis Pin	2